



golas y semiocultos

21.01

embutidos



21.02

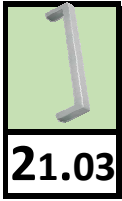

asas

21.03

tirador

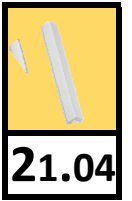

21.04



pomos

21.05

cuero



21.06



madera

21.07

vintage



21.08



clasico

21.09

porcelana , abs

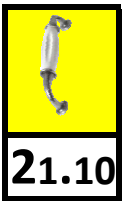

21.10

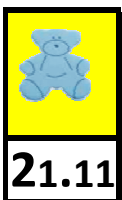

juvenil

21.11



tirador gola "L" para puertas

ALUMINIO

artículo	plata mate	efecto inox	blanco brillo	negro mate	SK	
1 perfil tirador 4 mts	113.811.860	113.811.941	113.811.871	113.811.882	✓	1
2 jgo tapas terminal interno	113.811.322	113.811.845	113.811.543	113.811.554	✓	1
3 rincon interno tirador	113.811.333	113.811.823	113.811.565	113.811.576	✓	1
4 rincon externo tirador	113.811.344	113.811.834	113.811.580	113.811.591	✓	1
5 kit accesorios fijacion	113.811.381	113.811.381	113.811.381	113.811.381	✓	1



①

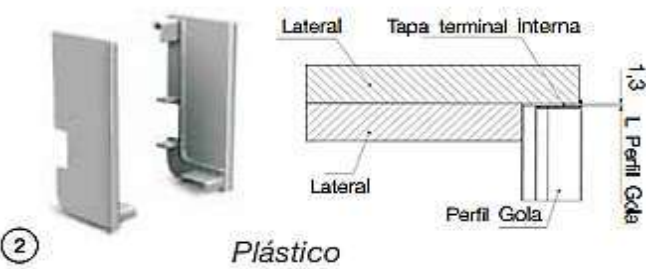
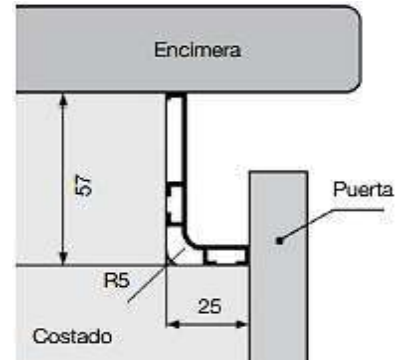

②

Plástico

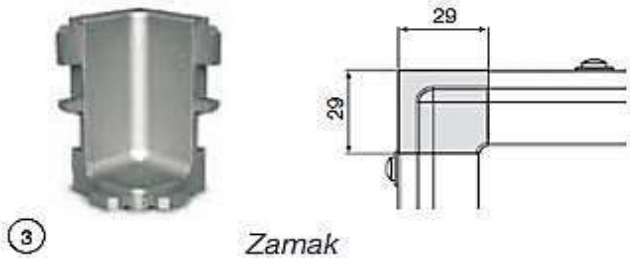

③

Zamak

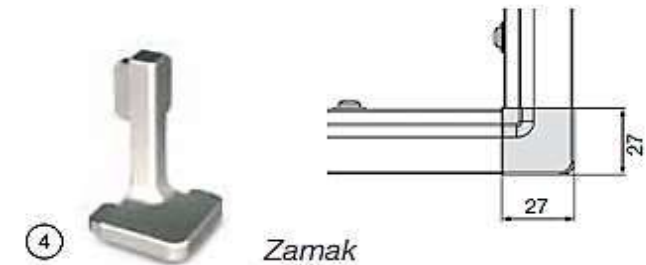

④

Zamak



⑤





21.01 tirador gola "U" para cajon

ALUMINIO

articulo	plata mate	efecto inox	blanco brillo	negro mate	SK	
1 perfil tirador 4 mts	113.811.904	113.811.952	113.811.915	113.811.926	✓	1
2 jgo tapas terminal interno	113.811.370	113.811.856	113.811.646	113.811.650	✓	1
3 kit accesorios fijacion	113.811.381	113.811.381	113.811.381	113.811.381	✓	1



1

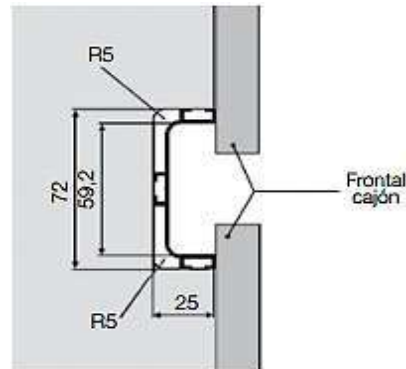

2

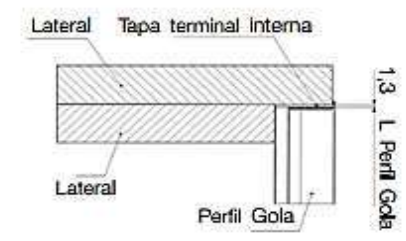

Plástico



3

tirador gola VERTICAL para columnas

articulo	plata mate	efecto inox	blanco brillo	negro mate	SK	
1 doble tira 2,30 mts	113.811.103	114.811.033	113.811.011	113.811.022	✓	1
2 simple tira 2,30 mts	113.811.114	114.811.125	113.811.136	113.811.140	✓	1



1

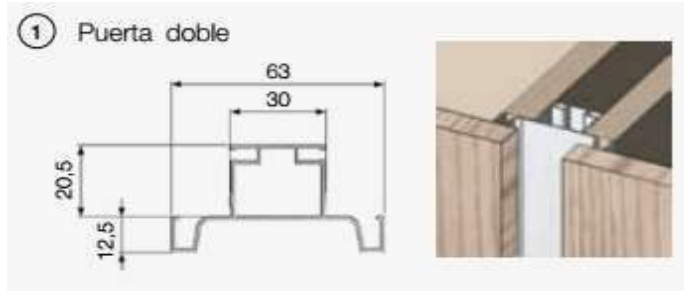

2

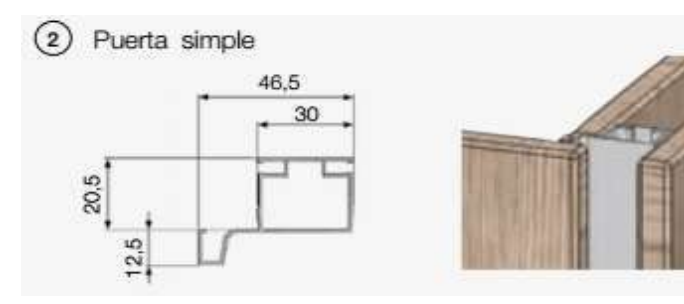

tiradores



tirador gola "H" mueble alto con goma amortiguador

ALUMINIO

largo	grueso tablero	blanco brillo	plata	SK	
tira 3 mts	16mm	113.811.256	113.811.263	✓	1
tira 3 mts	19mm	113.811.260	113.811.980	✓	1

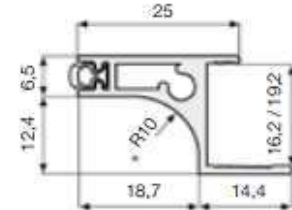
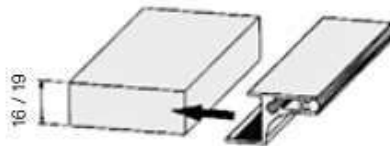
led ADAM para tirador gola

wattios mt	voltios	LM	nº leds	cortes	ancho	5500º blanco frio		2700º blanco calido		SK	
						1 mt	5 mt	1 mt	5 mt		
4,8 w	24 v	450 lm	60	100mm	8mm	232.811.950	232.811.961	232.811.935	232.811.946	✓	1
9,6 w	24 v	895 lm	120	50mm	8mm	232.811.994	232.811.005	232.811.972	232.811.983	✓	1

Características rollo LED:

- Rollo de 1 ó 5 metros provisto de cableado soldado para su conexión en ambos extremos (intentando evitar soldadura y conectores rápidos).
- Durabilidad de 50.000 horas
- Longitud máxima interconectable de 10 metros.
- No incluye fuente de alimentación, a elegir según el consumo en wattios y según la longitud en metros.
- Ángulo 120º.
- El modelo ADAM se caracteriza por más luminosidad, más homogeneidad de tonos lumínicos y una degradación del Led a las 50.000 horas del 10%.

Fuente de alimentación (no incluida):

elemento	wattios	medidas	referencia	SK	
fuelle alimentación	15	128x50x14	331.811.382	✓	1
fuelle alimentación	30	164x43x32	331.811.620	✓	1
fuelle alimentación	60	190x52x57	331.811.404	✓	1

Cables Led SMD con conector rápido (sin soldadura)

descripcion	ancho 8 mm	ancho 10 mm	SK	
cable empalme 150 mm	322.811.230	322.811.263	✓	1
cable alimentación 150 mm	322.811.226	322.811.252	✓	1
pieza empalme	322.811.241	322.811.274	✓	1



Empalme*



Alimentación



Pieza empalme

IMPORTANTE:

Los conectores rápidos no sirven para tiras Led con más de 80 Leds al disponer estas de muchos puntos de luz, en ese caso es imprescindible instalación mediante soldadura (tener en cuenta la polaridad)

Ejemplo de unión conector rápido (sin soldadura) + tira Led



21.01 tirador gola UNICO BILED para puertas **ILUMINADO**

ALUMINIO	artículo	plata mate	blanco mate	oro mate	antracina mate	SK	
1	perfil tirador 4 mts*	113.811.332	113.811.343	113.811.354	113.811.365	✓	1
2	tapa izq+der. Perfil	113.811.380	113.811.413	113.811.472	113.811.446	✓	1
3	rincon perfil	113.811.391	113.811.424	113.811.483	113.811.450	✓	1
4	esquina perfil	113.811.402	113.811.435	113.811.494	113.811.461	✓	1
5	escuadra fijacion	113.811.505	113.811.505	113.811.505	113.811.505	✓	1
6	cubierta PVC 2mm	113.811.376	113.811.376	113.811.376	113.811.376	✓	1

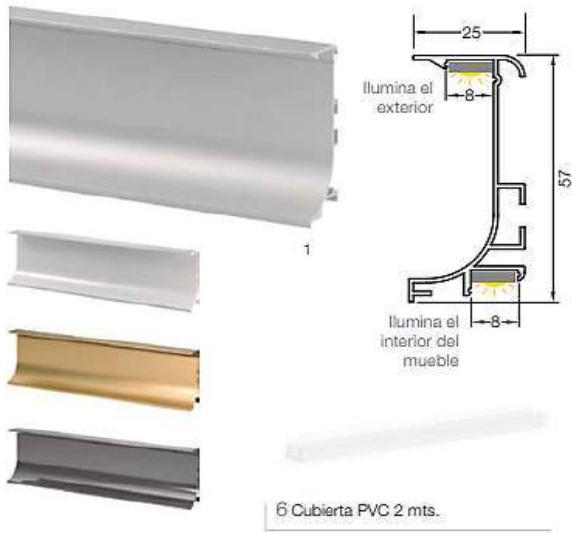

* Corte en 2 piezas para evitar recargo de transporte superior a 3 metros.

El mismo perfil sirve para puertas o cajones. Dependiendo de la colocación de la tira LED iluminaremos el perímetro o interior del mueble.



KIT ILUMINACION interior mueble



El kit incluye:
 1 - Led 4000°K (Luz neutra).
 2 - Sensor de apertura con encendido automático.
 3 - Cable conexión.
 4 - Cubierta PVC

potencia	largo	referencia	SK	
12w	1 mt	232.811.575	✓	1
24w	2 mts	232.811.586	✓	1



tirador mueble alto BILED para puertas **ILUMINADO**

ALUMINIO	grosso	largo	plata mate	blanco mate	antracina mate	SK	
	16 mm	4 mts*	113.811.516	113.811.520	113.811.531	✓	1
	19mm	4 mts*	113.811.542	113.811.553	113.811.564	✓	1

* Corte en 2 piezas para evitar recargo de transporte superior a 3 metros.

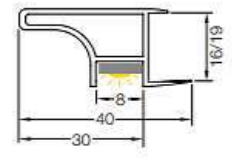
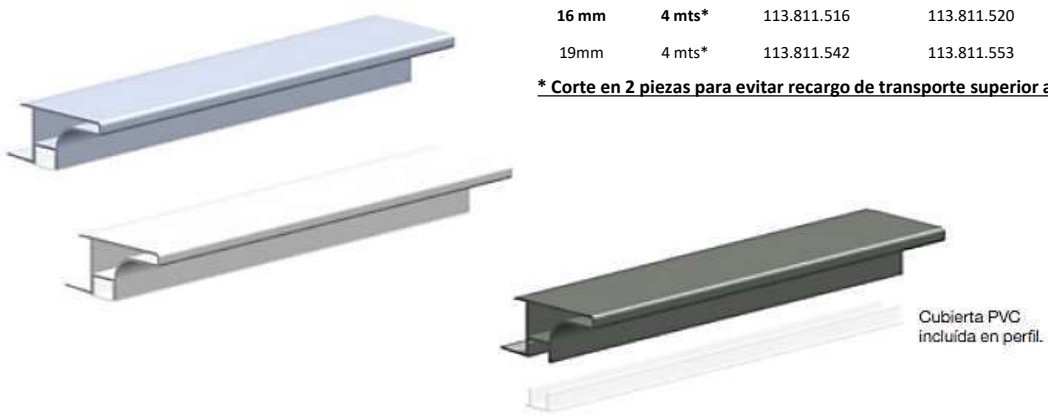

tiradores





tirador gola PLANO horizontal y vertical para puertas



descripcion	plata mate	efecto inox	blanco brillo	SK	
perfil tirador 4,7 mts	113.811.972	113.811.983	113.811.994	✓	1

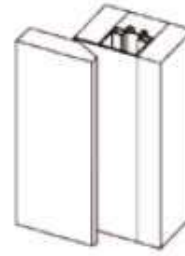
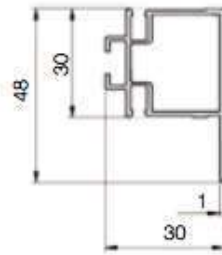

GOLA PLANO Vertical

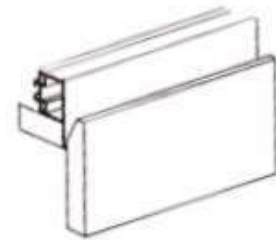

GOLA PLANO Horizontal

tirador gola PLANO horizontal y vertical para cajon



descripcion	plata mate	efecto inox	blanco brillo	SK	
perfil tirador 4,7 mts	113.811.005	113.811.016	113.811.965	✓	1

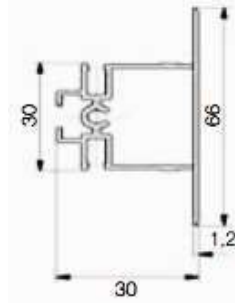

GOLA PLANO Vertical



GOLA PLANO Horizontal

tirador gola PLANO horizontal y vertical soportes y distanciadores



descripcion	negro	SK	
soporte	113.811.031	✓	1
distanciador	113.811.042	✓	1



tirador GRADA pestaña

ALUMINIO



mueble	A	plata mate	SK	
m-15	147	111.811.192	✓	1
m-20	197	111.811.203	✓	1
m-25	247	111.811.214	✓	1
m-30	297	111.811.225	✓	1
m-35	347	111.811.236	✓	1
m-40	397	111.811.240	✓	1
m-45	447	111.811.251	✓	1
m-50	497	111.811.262	✓	1
m-60	597	111.811.273	✓	1
m-70	697	111.811.284	✓	1
m-80	797	111.811.295	✓	1
m-90	897	111.811.306	✓	1
m-100	997	111.811.310	✓	1
m-120	1197	111.811.321	✓	1
barra 3 mts		111.811.332	✓	1

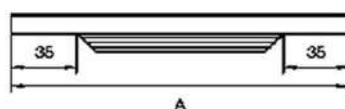
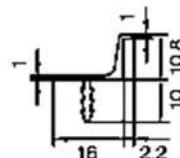

✓ = stock

p = bajo pedido

tiradores



21.01 tirador gola TOUCH para puertas

ALUMINIO/zamak

artículo	chromo mate	SK	
kit perfil 1 mt+2 bisagras	113.811.924		15
kit 1 perfil 3 mts+6 bisagras	113.811.854		15
bisagra suelta	113.811.865		1



Permite instalación a todo el largo de la puerta o cajón, o a la medida que se desee. El perfil de aluminio satinado viene provisto de tratamiento para poderlo lacar al color de la puerta y permitir integrarlo al diseño necesario.

Este revolucionario producto permite embutir un perfil tirador con bisagra en cualquier cajón para mueble o puerta de armario corredera. Un estilizado perfil de tres metros en acabado chromo mate le permitirá, por ejemplo, instalar un perfil que abarque toda la altura de un armario corredero. Aunque si lo prefiere puede cortar dicho perfil e instalar su tirador TOUCH a la medida que desee.

La personalización que ofrece el sistema TOUCH no se queda ahí, el perfil de aluminio satinado en acabado chromo mate viene provisto de un tratamiento para poderlo lacar al color de la puerta del mueble o el armario. Así podemos integrar el sistema TOUCH en cualquier tipo de diseño. Súbase al carro de la personalización, del minimalismo, del detalle y de la calidad con el sistema perfil TOUCH.

Medidas bisagra

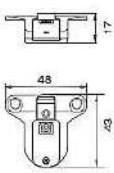

Número de bisagras según puerta

Puerta	Bisagras
150 a 1099 mm.	2
1100 a 1599 mm.	3
1600 a 2099 mm.	4
2100 a 2599 mm.	5
2600 a 3000 mm.	6

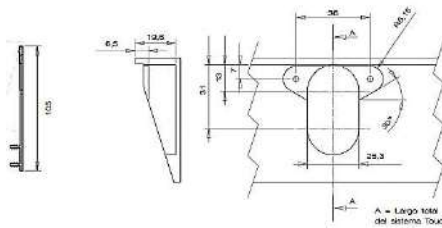

Ejemplar de montaje

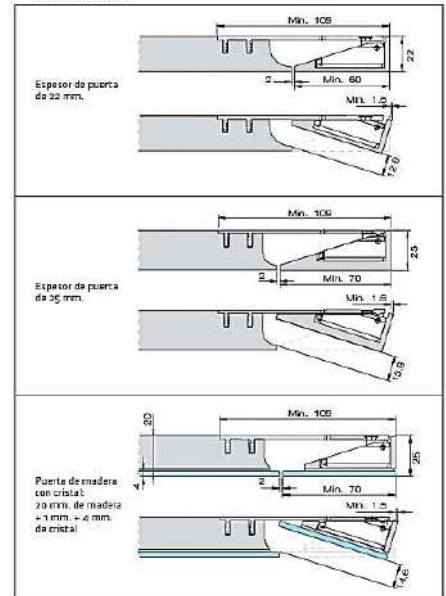

tirador MITER angulo cualquier grueso puerta

ALUMINIO

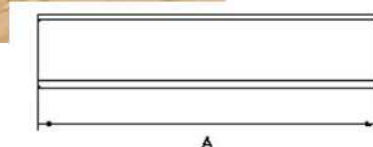
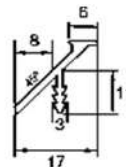

mueble	A	plata mate	SK	
m-15	147	112.811.192		1
m-20	197	112.811.203		1
m-25	247	112.811.214		1
m-30	297	112.811.225		1
m-35	347	112.811.236		1
m-40	397	112.811.240		1
m-45	447	112.811.252		1
m-50	497	112.811.262		1
m-60	597	112.811.273		1
m-70	697	112.811.284		1
m-80	797	112.811.295		1
m-90	897	112.811.306		1
m-100	997	112.811.310		1
m-120	1197	112.811.321		1

tirador JEV pestaña

ALUMINIO

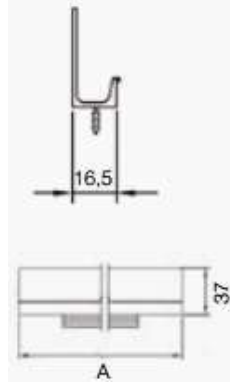

mueble	A	efecto inox	SK	
m-15	147	111.811.985	✓	1
m-20	197	111.811.926	✓	1
m-25	247	111.811.000	✓	1
m-30	297	111.811.011	✓	1
m-35	347	111.811.022	✓	1
m-40	397	111.811.033	✓	1
m-45	447	111.811.044	✓	1
m-50	497	111.811.055	✓	1
m-60	597	111.811.066	✓	1
m-70	697	111.811.070	✓	1
m-80	797	111.811.081	✓	1
m-90	897	111.811.092	✓	1
m-100	997	111.811.103	✓	1
m-120	1197	111.811.114	✓	1

tirador JEV-2 pestaña

ALUMINIO



mueble	A	efecto inox	SK	
m-15	147	111.811.674	✓	1
m-20	197	111.811.675	✓	1
m-25	247	111.811.696	✓	1
m-30	297	111.811.700	✓	1
m-35	347	111.811.721	✓	1
m-40	397	111.811.722	✓	1
m-45	447	111.811.733	✓	1
m-50	497	111.811.744	✓	1
m-60	597	111.811.755	✓	1
m-70	697	111.811.766	✓	1
m-80	797	111.811.770	✓	1
m-90	897	111.811.781	✓	1
m-100	997	111.811.792	✓	1
m-120	1197	111.811.823	✓	1

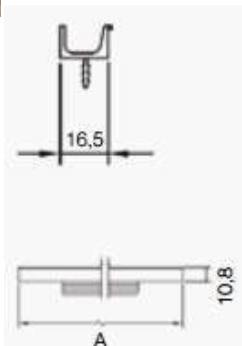

tirador GOBE pestaña

ALUMINIO

Permite cualquier grueso de puerta al no tener pestaña posterior.

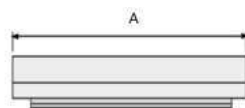
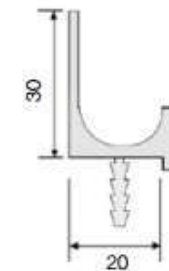

mueble	A	efecto inox	SK	
m-25	247	111.811.686	✓	1
m-30	297	111.811.690	✓	1
m-35	347	111.811.701	✓	1
m-40	397	111.811.712	✓	1
m-45	447	111.811.723	✓	1
m-50	497	111.811.734	✓	1
m-60	597	111.811.745	✓	1
m-70	697	111.811.756	✓	1
m-80	797	111.811.760	✓	1
m-90	897	111.811.771	✓	1
m-100	997	111.811.782	✓	1
m-120	1197	111.811.793	✓	1





21.01 tirador TECNO pestaña

ALUMINIO

Permite cualquier grueso de puerta al no tener pestaña posterior.



mueble	A	B	efecto inox	SK	
m-25	247	207	111.811.660	✓	1
m-30	297	257	111.811.671	✓	1
m-35	347	307	111.811.682	✓	1
m-40	397	357	111.811.693	✓	1
m-45	447	407	111.811.704	✓	1
m-50	497	457	111.811.715	✓	1
m-60	597	557	111.811.726	✓	1
m-70	697	657	111.811.730	✓	1
m-80	797	757	111.811.741	✓	1
m-90	897	857	111.811.752	✓	1
m-100	997	967	111.811.773	✓	1
m-120	1197	1157	111.811.784	✓	1

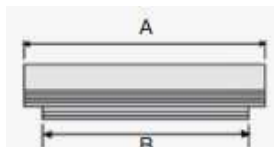
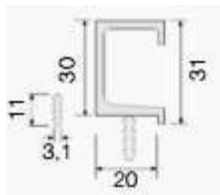

tirador SWING

ACERO INOX

C	L	acero inox	SK	
16	32	111.811.245	✓	1

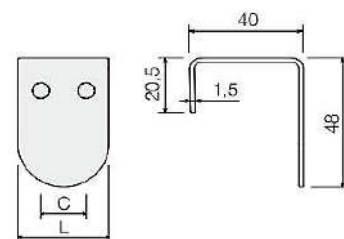

tirador EDGE FILIGREE

ALUMINIO

Fácil instalación

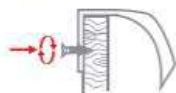

* Tiradores con 3 agujeros a 80 mm de distancia

		titanio cepillado	SK	
20	60	111.811.024	✓	1
160*	176	111.811.035	✓	1

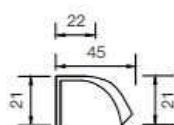

tirador ONIDA

ACERO

		plata vieja	negro industrial	SK	
20		111.811.774	111.811.763	✓	1
160	200	111.811.996	111.811.785	✓	1



Fácil instalación

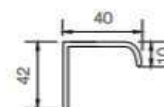
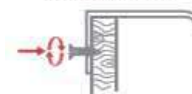

tirador EDGE STRAIGHT

ALUMINIO

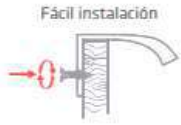

			oro mate	oro rosa mate	moka	negro cepillado	SK	
	20	40	111.811.803	111.811.845	111.811.840	111.811.002	✓	
	160*	200	111.811.814	111.811.836	111.811.851	111.811.013	✓	1

* Tiradores con 3 agujeros a 80 mm de distancia

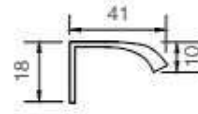

tirador EDGE ROUND

ALUMINIO

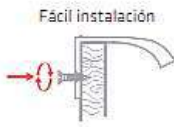

			efecto inox	SK	
	20	40	111.811.416	✓	1
	160*	200	111.811.420	✓	1

* Tiradores con 3 agujeros a 80 mm de distancia

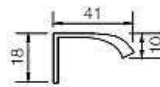

tirador IZAR adhesivo directo al canto de la puerta

ALUMINIO

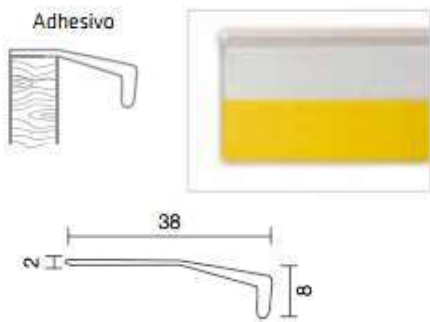

			aluminio plata	SK	
	adhesivo	150	111.811.990	✓	1



placa MOLTO Adhesiva para puertas push

ALUMINIO



	medida	espesor	inox mate	SK	
	30x3	0,2	111.811.666	✓	1



Placa indicadora para facilitar la apertura en ins- talación en puertas o cajones con apertura "push" (o toca-toca).

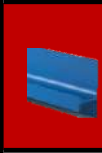

21.01 tirador LINEAR con pestaña efecto inox

ALUMINIO

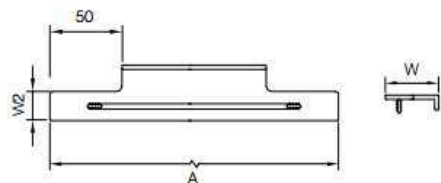

Puerta 19 mm. W2 = 19,8 mm. / W = 37 mm.
Puerta 20,5 mm. W2 = 21 mm. / W = 38,5 mm.

mueble	A	puerta 19mm	puerta 20,5mm	SK	
m-15	148	111.811.316	111.811.456	✓	1
m-20	198	111.811.320	111.811.460	✓	1
m-25	248	111.811.331	111.811.471	✓	1
m-30	298	111.811.342	111.811.482	✓	1
m-35	348	111.811.353	111.811.493	✓	1
m-40	398	111.811.364	111.811.504	✓	1
m-45	448	111.811.375	111.811.515	✓	1
m-50	498	111.811.386	111.811.526	✓	1
m-60	598	111.811.390	111.811.530	✓	1
m-70	698	111.811.401	111.811.541	✓	1
m-80	798	111.811.412	111.811.552	✓	1
m-90	898	111.811.423	111.811.563	✓	1
m-100	998	111.811.434	111.811.574	✓	1
m-120	1198	111.811.445	111.811.585	✓	1

tirador FORMA con pestaña efecto inox

ALUMINIO

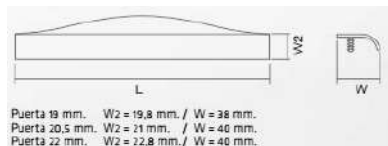

Puerta 19 mm. W2 = 19,8 mm. / W = 38 mm.
Puerta 20,5 mm. W2 = 21 mm. / W = 40 mm.
Puerta 22 mm. W2 = 22,8 mm. / W = 40 mm.



mueble	L	puerta 19mm	puerta 20,5mm	puerta 22mm	SK	
m-15	147	✓ 101.811.850	101.811.990	101.811.130	P	1
m-20	197	✓ 101.811.861	101.811.001	101.811.141	P	1
m-25	247	✓ 101.811.872	101.811.012	101.811.152	P	1
m-30	297	✓ 101.811.883	101.811.023	101.811.163	P	1
m-35	347	✓ 101.811.894	101.811.034	101.811.174	P	1
m-40	397	✓ 101.811.905	101.811.045	101.811.185	P	1
m-45	447	✓ 101.811.916	101.811.056	101.811.196	P	1
m-50	497	✓ 101.811.920	101.811.060	101.811.200	P	1
m-60	597	✓ 101.811.931	101.811.071	101.811.211	P	1
m-70	697	✓ 101.811.942	101.811.082	101.811.222	P	1
m-80	797	✓ 101.811.953	101.811.093	101.811.233	P	1
m-90	897	✓ 101.811.964	101.811.104	101.811.244	P	1
m-100	997	✓ 101.811.975	101.811.115	101.811.255	P	1
m-120	1197	✓ 101.811.846	101.811.986	101.811.126	P	1

tirador TURIN mecanizacion teton

ZAMAK

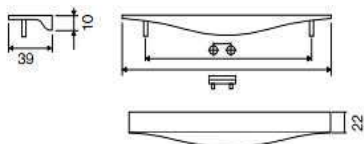

		efecto inox mate	Cromo brillo	SK	
96	146	111.811.999	111.811.130	✓	1
192	280	111.811.001	111.811.141	✓	1
384	446	111.811.012	111.811.152	✓	1



tiradores



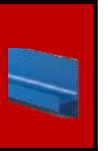

21.01

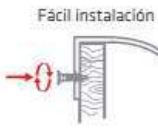
tirador EMOTIONS TWO atornillar
ALUMINIO

*3 agujeros, múltiplo 256

			efecto inox	blanco mate	negro mate	SK	
	128	200	111.811.740	111.811.681	111.811.714	✓	1
	256	350	111.811.751	111.811.692	111.811.725	✓	1
	512*	650	111.811.670	111.811.703	111.811.736	✓	1

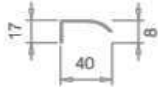
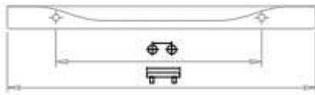
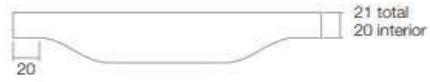

 Nota: Se pueden fabricar medidas especiales bajo encargo.
 Pedido mínimo de 200 uds en medidas cortas y 100 en largas

tirador LIPS atornillar
ALUMINIO

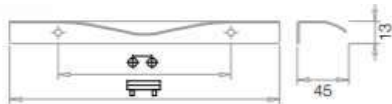
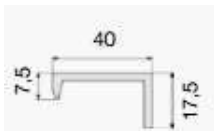

			Cromo brillo	efec. inox mate	SK		
	45	160	200	111.811.484	111.811.673	✓	1
	45	224	350	113.811.506	113.811.495	✓	1

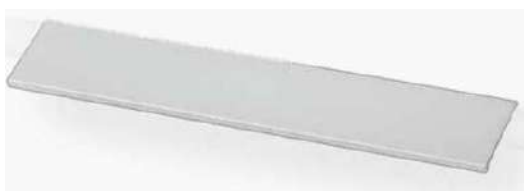
tirador SLIM-2
ALUMINIO

		aluminio plata	Cromo brillo	blanco mate	negro mate	SK	
	40			111.811.790	111.811.393	✓	1
	230	111.811.323	111.811.334	111.811.786	111.811.356	✓	1
	2000	111.811.404				✓	1

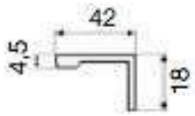

21.01 ALUMINIO



*5 agujeros, múltiplo 224.

			aluminio plata	SK	
	32	40	111.811.842	✓	1
	160	192	111.811.853	✓	1
5 agujeros, múltiplo 224.	896	1000	111.811.864	✓	1

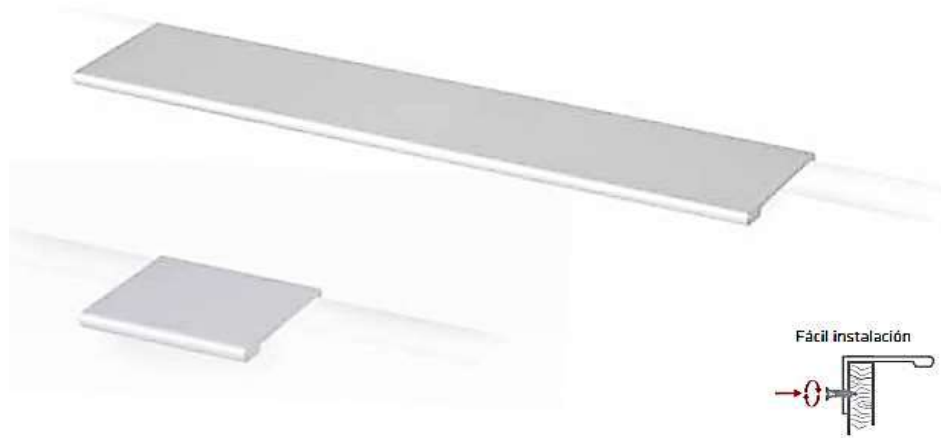

tirador RESORT

ALUMINIO



			titanio	efec.inox mate	blanco mate	negro mate	SK	
	128	200	111.811.600	111.811.570	111.811.581	111.811.592	✓	1

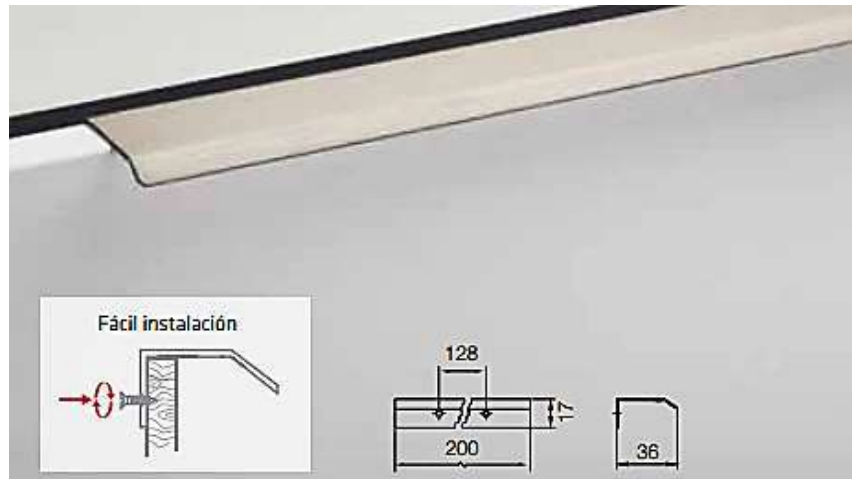

tirador IN

ACERO INOX

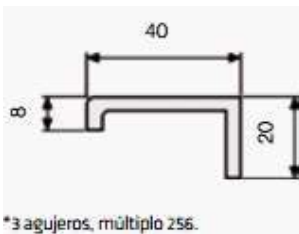

*3 agujeros, múltiplo 256.

			acero inox	SK	
	16	146	111.811.735	✓	1
	128	280	111.811.746	✓	1
	224	446	111.811.750	✓	1
	512*	544	111.811.761	✓	1





tirador THAOS

ZAMAK



		exterior	encastre	efec.inox mate	SK	
32		45x45x2	40x36x14	119.811.025	✓	1
160		173x45x2	168x15x14	119.811.040	✓	1



tirador MEDA

ALUMINIO



		exterior	encastre	aluminio plata	SK	
64		102X62X3	94X53X15,5	119.811.876	✓	1
160		198X62X3	190X53X15,5	119.811.880	✓	1

tirador SCENE

ZAMAK



		exterior	encastre	chromo mate	SK	
64		80x80x2	76x76x14	119.811.675	✓	1

tirador SEIZE

ZAMAK



		exterior	encastre	chromo mate	SK	
160		180x50x2	175x45x16	119.811.642	✓	1





21.02 tirador HIDE trasero

ZAMAK

		blanco mate	negro mate	efec. inox mat	SK	
128	180	119.811.585	119.811.596	119.811.911	✓ ✓	1

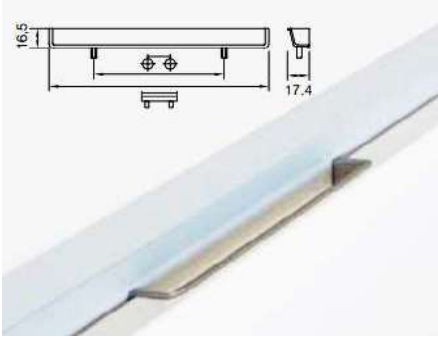

tirador KORU

ZAMAK

	exterior	acero negro	plata vieja	SK	
64	73x73x3	119.811.313	119.811.324	✓	1

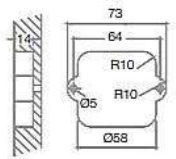

tirador SEIZE 2

ZAMAK

	exterior	encastre	chromo look	SK	
160	180x45x2	168x40x16	119.811.653	✓	1



tirador y tapa LIKE efecto inox mate

ZAMAK

		puerta 19	puerta 20,5	SK	
202	212	119.811.885	119.811.896	✓	1

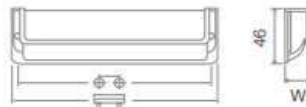

Puerta 19 mm. W = 18,6 mm.
Puerta 20,5 mm. W = 20,6 mm.

Disponemos de plano para el mecanizado con control numérico.



TAPA LIKE efecto inox mate

ZAMAK

		efec.inox mat	SK	
202	212	119.811.900	✓	1

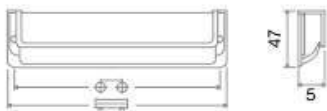

tirador FUMI

ZAMAK

		efec.inox mat	SK	
160	174,8	119.811.270	✓	1

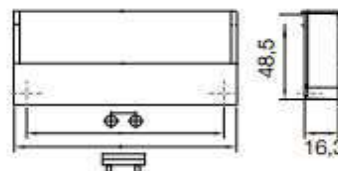

tirador FLUSH

ZAMAK

	exterior	encastre	efec.inox mat	SK	
32	58x71x2	44x55x14	119.811.475	✓	1



tirador TOTE

ACERO INOX

exterior	encastre	inox mate	SK	
50X50X2	D:40X10	114.811.065	✓	1
70X70X2	D:54X12	114.811.076	✓	1
150X50X2	122X28X12	114.811.080	✓	1

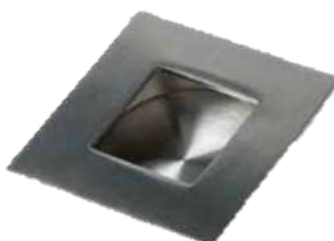



embutidos

21.02 tirador RASO

ZAMAK



		exterior	encastre	efect.inox mat	SK	
		32	70x57x2	58x47x14	119.811.395	✓ 1
		108	152x57x2	140x47x2	119.811.410	✓ 1

tirador LOW

ZAMAK



		exterior	encastre	efect.inox mat	chromo brillo	SK	
		64	78X52	60x46x13,5	114.811.776	✓	1
		192	206X52	182x46x13,5	115.811.791	115.811.780	✓ 1



tirador TIFANY

ZAMAK

	exterior	encastre	efect.inox mat	SK	
	150X25	147X22X11	114.811.613	✓	1
	240X25	237X22X11	114811624	✓	1



tirador DANTE

ALUMINIO



	exterior	encastre	chromo mate	SK	
	256x80x1,5	252x76x16	114.811.655	✓	1

tirador IRIS

ALUMINIO

		exterior	encastre	negro mate	blanco mate	chromo look	SK	
192		202x39x3	198x34x12	114.811.985	114.811.974	114.811.285	✓	1



Permite cortarse a medida

tirador MUNICH

ZAMAK

		exterior	encastre	chromo look	SK	
96		160x24x1,6	157x21x12	114.811.206	✓	1

tirador KOBE

ACERO INOX

	exterior	encastre	inox mate	SK	
	50X50X2	D:40X10	114.811.950	✓	1

tirador JAM

ACERO INOX

	exterior	encastre	inox mate	SK	
	D:65x2	D:51x12	114.811.244	✓	1
	120x40x2	92x28x12	114.811.255	✓	1



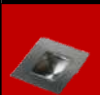

21.02 tirador ECO-NOE

ZAMAK



descripcion	exterior	encastre	negro	efecto inox	SK	
cazoleta ciega	D:57x2	D:48x7		114.811.745	✓	1
dedal	D:57x2	D:48x7	128.131.208	114.811.756	✓	1



DEDAL NOE

LATON



mod.	descripcion	exterior	encastre	acabado	referencia	SK	
3	dedal	D:29x2	D:25x9	chromo mate	114.811.990	✓	1
3	dedal	D:29x2	D:25x9	chromo brillo	114.811.986	✓	1
3	dedal	D:29x2	D:25x9	pulido brillo	114.811.953	✓	1
3	dedal	D:29x2	D:25x9	efecto inox	114.811.001	✓	1
3	dedal	D:29x2	D:25x9	cuero	114.811.975	✓	1

tirador ECO-NIKO

ZAMAK



descripcion	exterior	encastre	laton pulido	efecto inox	SK	
cazoleta ciega	55x55x2	D:48x7		114.811.760	✓	1
dedal			128.131.701	128.131.702	✓	1

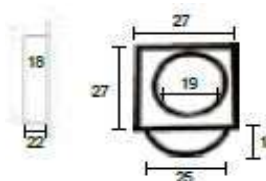

tirador TITO

ZAMAK



	exterior	encastre	negro mate	blanco mate	chromo mate	SK	
	D:40X2,5	D:35X11	114.811.816	114.811.820	114.811.296	✓	1

TIRADOR NOE OVAL

LATON



	exterior	encastre	acabado	referencia	SK	
	150X40	103X26X11	chromo mate	114.811.144	✓	1
	150X40	103X26X11	chromo brillo	114.811.133	✓	1
	150X40	103X26X11	dorado brillo	114.811.122	✓	1
	150X40	103X26X11	efecto inox mate	114.811.096	✓	1
	150X40	103X26X11	laton oxidado	114.811.100	✓	1

tiradores





tirador ERIC

ACERO INOX



exterior	encastre	inox mate	SK	
75x75	70x70	114.811.993	✓	1
154x45x2	150x40x17	114.811.012	✓	1

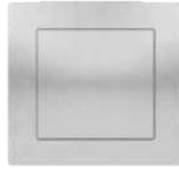

No tiene pestaña interio. Indicado para puertas correderas

tirador ERIC

ACERO INOX



exterior	encastre	inox mate	SK	
D:75	D:71	115.811.982	✓	1
155x45x2	150x40x17	115.811.001	✓	1



tirador ROLLER

ZAMAK



			cromo look	SK	
32	32	33	114.811.761	✓	1

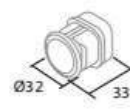

tirador STYLUS

ZAMAK



exterior	encastre	inox mate	SK	
39X39	D:35	114.811.085	✓	1

tirador CUBIC

ZAMAK



exterior	encastre	negro mate	blanco mate	SK	
160X23,6X10	156,4X20X8,8	114.811.261	114.811.250	✓	1

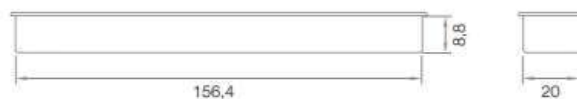



21.02 tirador CLOS

ZAMAK

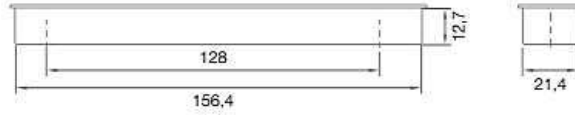

	exterior	encastre	negro mate	blanco mate	SK	
128	160X25X14	156,5X21,4X12,7	114.811.283	114.811.272	✓	1

tirador sobrepuesto adhesivo PLEC

ACERO INOX



				inox mate	SK	
75	75	6	115.811.281	✓	2	
75	150	6	115.811.292	✓	2	

Incluye adhesivo 3M.
También permite instalarse adhesivo ultravioleta

tirador asa NIDIA

ACERO INOX



mueble					inox mate	SK	
30	128	192	12	37	111.811.630	✓	1
45	292	356	12	37	111.811.663	✓	1
60	442	506	12	37	111.811.685	✓	1
90	742	806	12	37	111.811.711	✓	1

tirador asa HIOS

ACERO INOX



				inox mate	SK	
192	202	20	35	111.811.501	✓	1

tirador asa KUBE

ACERO INOX



mueble					inox mate	SK	
30/35	192	204	12	40	111.811.065	✓	1
40/50	320	332	12	40	111.811.076	✓	1
60/70	512	524	12	40	111.811.080	✓	1

tirador asa FERRI

ACERO INOX



				inox brillo	SK	
128	140	12	35	111.811.802	✓	1
192	204	12	35	111.811.813	✓	1
320	332	12	35	111.811.824	✓	1
512	524	12	35	111.811.835	✓	1



tirador asa

21.03 tirador asa PRIMO SLIM

ALUMINIO

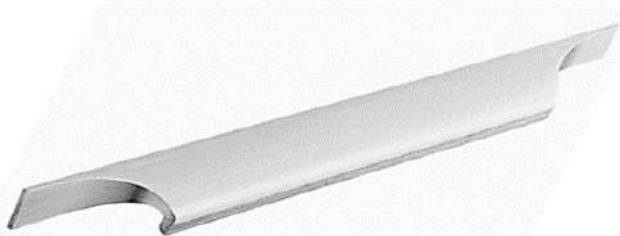

					efec. inox mat	SK	
2X85	289	16	19	113.811.431	✓	1	
2X135	389	16	19	113.811.442	✓	1	
2X123	489	16	19	113.811.453	✓	1	
2X167	789	16	19	113.811.464	✓	1	

tirador asa TAMM

ALUMINIO

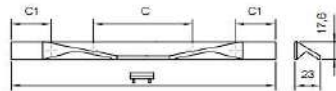

	mueble		C	C1	efec. inox mat	SK	
15	140	32	54	113.811.491	✓	1	
20	190	64	63	113.811.502	✓	1	
25	240	128	56	113.811.513	✓	1	
30	290	160	58	113.811.524	✓	1	
35	340	192	58	113.811.535	✓	1	
40	390	256	58	113.811.546	✓	1	
45	440	256	58	113.811.550	✓	1	
50	490	320	58	113.811.561	✓	1	
60	590	448	58	113.811.572	✓	1	
70	690	512	58	113.811.583	✓	1	
80	790	608	58	113.811.594	✓	1	
90	890	704	58	113.811.605	✓	1	
100	990	832	58	113.811.616	✓	1	
120	1190	1024	58	113.811.480	✓	1	

tirador asa KEIZO

ALUMINIO



					aluminio inox	SK	
160-768*	815	8	32	119.811.831	✓	1	

* cuatro agujeros.

tirador asa AKER

ALUMINIO



	mueble					aluminio mate	SK	
30-35	192	242	10	32	111.811.276	✓	1	
40-45	292	342	10	32	111.811.280	✓	1	

tirador asa SENSE MINI

ALUMINIO



					negro mate	SK	
96	103	17	30	114.811.783	✓	1	
160	167	17	30	114.811.794	✓	1	
256	263	17	30	114.811.805	✓	1	

tirador asa STELA

ZAMAK



					aluminio look	SK	
16	30	20	20	113.811.373	✓	1	
96	110	20	24	113.811.340	✓	1	
160	174	20	26	113.811.361	✓	1	

Especialmente indicados para perfil de vitrina

tirador FABIO

ZAMAK

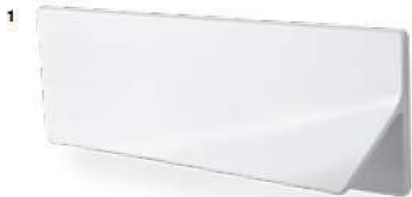

					chromo look	blanco mate	chromo brillo	SK	
1	32	50	50	26	113.811.736	113.811.740	113.811.751	✓	1
2	32	160	32	24	113.811.670	113.811.681	113.811.692	✓	1

El acabado blanco mate permite lacarse para integrarlo en el mismo acabado de la puerta

tirador asa ERNEST

ALUMINIO

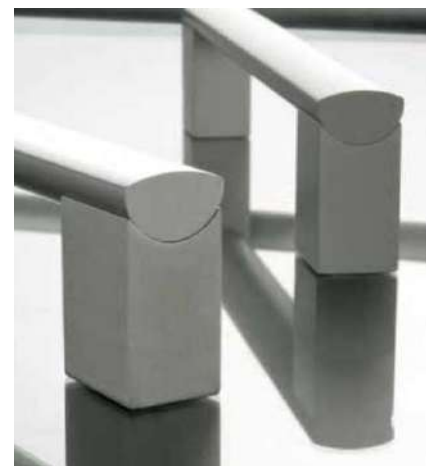

mueble					aluminio mate	SK	
30-35-40	160	186	16	36	113.811.113	✓	1
40-45-50	292	300	16	36	113.811.523	✓	1



tirador asa

21.03 tirador asa CUBO

ZAMAK

				chromo look	blanco brillo	negro mate	SK	
128-160*	173	25	30	111.811.410			✓	1
160-192+	205	25	30	111.811.795	111.811.091	111.811.102	✓	1



* cuatro agujeros.



tirador asa ROXAN

ZAMAK

				chromo mate	SK	
160	174	14	21	113.811.271	✓	1



tirador asa TWIN

ALUMINIO

				aluminio mate	SK	
192	200	20	34	114.811.740	✓	1



tirador asa SENSE

ALUMINIO

				negro cepillado	ef.inox mate	chromo brillo	SK	
128	135	25	29,5	114.811.590	114.811.504	114.811.541	✓	1
192	199	25	29,5	114.811.601	114.811.515	114.811.552	✓	1
320	327	25	29,5	114.811.612	114.811.526	114.811.563	✓	1
480	487	25	29,5	114.811.623	114.811.530		✓	1



tirador asa LEO

ZAMAK

96	148	16	26	chromo mate	SK	
96	148	16	26	113.811.293	✓	1

tirador asa VENUS

ZAMAK

160	175	13	29	efecto inox	chromo brillo	SK	
160	175	13	29	113.811.023	113.811.034	✓	1
256	280	14	35	113.88.435		✓	1
384	408	14	38	113.811.454		✓	1

tirador asa LORIS

ZAMAK

160	200	11	25	efecto inox	chromo brillo	SK	
160	200	11	25	114.811.620	114.811.650	✓	1
256	264	11	27	114.811.631	114.811.661	✓	1

tirador KARES

ZAMAK

96	152	20	20	ef.inox mate	blanco mate	SK	
96	152	20	20	113.811.432	113.811.443	✓	1
192	312	20	20	113.811.465	113.811.476	✓	1

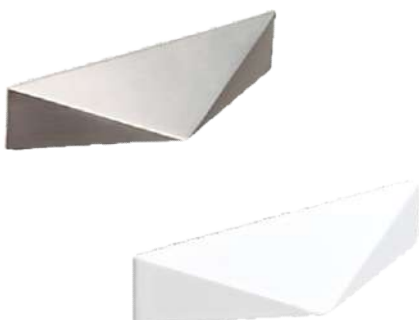



tirador asa

21.03 tirador asa carrusel GUALTE

ACERO INOX

				inox mate	SK	
96	104	8	30	111.811.683	✓	1
192	200	8	30	111.811.705	✓	1



tirador asa CARRUSEL 1

ZAMAK		chromo br	oro	chromo mt	epoxi pintura	niquel sat.	cuero decor.	SK	
64	111.189.001	111.389.010	111.389.019	111.389.019	111.389.xxx	111.389.280	111.389.289		10
96	111.189.002	111.389.011	111.389.020	111.389.020	111.389.xxx	111.389.281	111.389.290		10
128	111.189.003	111.389.012	111.389.021	111.389.021	111.389.xxx	111.389.282	111.389.291		10
160	111.189.004	111.389.013	111.389.022	111.389.022	111.389.xxx	111.389.283	111.389.292		10
192	111.189.005	111.389.014	111.389.023	111.389.023	111.389.xxx	111.389.284	111.389.293		10
224	111.189.006	111.389.015	111.389.024	111.389.024	111.389.xxx	111.389.285	111.389.294		10
256	111.189.007	111.389.016	111.389.025	111.389.025	111.389.xxx	111.389.286	111.389.295		10
288	111.189.008	111.389.017	111.389.026	111.389.026	111.389.xxx	111.389.287	111.389.296		10
320	111.189.009	111.389.018	111.389.027	111.389.027	111.389.xxx	111.389.288	111.389.297		10



64	72	30	8
96	105	30	9
128	137	30	9
160	169	30	9
192	201	30	9
224	233	30	9
256	265	30	9
288	297	30	9
320	329	30	9

Para pedidos color epoxi indicar el color RAL.

COLORES EPOXI / EPOXY COLORS



tiradores



f

p= bajo pedido

✓= stock

tirador asa ATLANTE ACERO INOX

ACERO INOX



mueble					inox mate	SK	
25-30	192	214	14	44	111.811.491	✓	1
35	242	264	14	44	111.811.946	✓	1
40	292	314	14	44	111.811.502	✓	1
45	342	364	14	44	111.811.513	✓	1
50	392	414	14	44	111.811.524	✓	1
60	492	514	14	44	111.811.535	✓	1
70	592	614	14	44	111.811.546	✓	1
80	692	714	14	44	111.811.961	✓	1
90	792	814	14	44	111.811.550	✓	1
120*	1092	1114	14	44	111.811.972	✓	1

* con pata central

tirador asa ATLANTE ALUMINIO

ALUMINIO



				aluminio mate	SK	
1092*	1114	14	44	111.811.075	✓	1

* con pata central

tirador asa GREEN

ACERO INOX



mueble					inox mate	SK	
25-30	192	214	12	35	111.811.372	✓	1
35-40	292	314	12	35	111.811.383	✓	1
55-60	492	514	12	35	111.811.394	✓	1

tirador asa ARCH

ZAMAK



				chromo brillo	efecto inox	SK	
192	208,5	14,5	36	113.811.710	113.811.721	✓	1



tirador asa

21.03 tirador asa FLAT

ACERO INOX

					inox mate	SK	
	16	36	30	30	111.811.691	✓	1
	160	166	30	30	111.811.702	✓	1
	320	326	30	30	111.811.713	✓	1



tirador asa QATAR

ZAMAK

					ef.inox mate	SK	
	192	260	27	31	113.811.351	✓	1



tirador asa MODULAR

ACERO INOX

mueble						inox mate	SK	
M-25	128	192	12	35	111.811.195	✓	1	
universal	160	220	12	35	111.811.136	✓	1	
M-30	192	256	12	35	111.811.206	✓	1	
M-35	242	306	12	35	111.811.210	✓	1	
M-40	292	356	12	35	111.811.221	✓	1	
M-45	342	406	12	35	111.811.232	✓	1	
M-50	392	456	12	35	111.811.243	✓	1	
M-55	452	516	12	35	111.811.621	✓	1	
M-60	492	556	12	35	111.811.254	✓	1	
M-70	592	656	12	35	111.811.050	✓	1	
M-80	692	756	12	35	111.811.632	✓	1	
M-90	792	856	12	35	111.811.265	✓	1	
M-120*	1092*	1156	12	35	111.811.995	✓	1	



*Con pata central

placa soporte para instalar cualquier tirador sin taladro pasante

ZAMAK

ancho	fondo	alto	niquelado	SK	
40	15	3	103.811.462	✓	1



Placa Soporte para instalación de tiradores con fijación vista

Monte cualquier tirador como un toallero o manillón





tirador TEY

ZAMAK

				chromo mate	SK	
96	150	41	25	113.811.785	✓	1



tirador asa ARROW





ZAMAK

				ef.inox mate	SK	
192	223	20	36	113.811.732	✓	1



tirador asa PLANAR





ZAMAK

				ef.inox mate	SK	
128	150	10	35	113.811.716	✓	1
192	214	10	35	113.811.720	✓	1
320	342	10	35	113.811.731	✓	1



tirador asa DUAL

ZAMAK

				chromo brillo	chromo mate	SK	
16	26	10	26	113.811.776	113.811.802	✓	1
128	137	10	26	113.811.765	113.811.791	✓	1
192	201	10	26	113.811.755	113.811.780	✓	1





tirador asa

21.03 tirador asa BASIC

ZAMAK



					chromo look	SK	
	128	168	14	36	111.811.432	✓	1
	192	232	14	36	111.811.806	✓	1

tirador asa QUANTO

					chromo look	chromo brillo	blanco brillo	negro mate	SK	
	32	41	7	24	116.811.193				✓	1
	96	105	7	28	116.811.172					1
	128	137	7	28	116.811.204	116.811.171	116.811.113	116.811.124	✓	1
	224	233	7	28	116.811.150				✓	1
	320	329	7	28	116.811.215	116.811.182	116.811.135	116.811.146	✓	1



tirador asa BERLIN

ZAMAK



					ef.inox mate	chromo brillo	SK	
	192	211	12	33	113.811.672	113.811.694	✓	1
	256	275	12	33	113.811.683	113.811.705	✓	1

tirador asa KAMON

ZAMAK



					ef.inox mate	chromo brillo	SK	
	160	170	19	26	113.811.651	113.811.662	✓	1
	320	340	19	26	113.811.673	113.811.684	✓	1

tiradores



p= bajo pedido

✓= stock

tirador asa DINO ZAMAK

					cromo brillo	cromo look	blanco mate	negro mate	SK	
96-128	156	7	24		111.811.211	111.811.222	111.811.233	111.811.244	✓	1
160-192	221	7	28		111.811.255	111.811.266	111.811.270	111.811.281	✓	1
288-320	349	7	28		111.811.292	111.811.303	111.811.314	111.811.325	✓	1

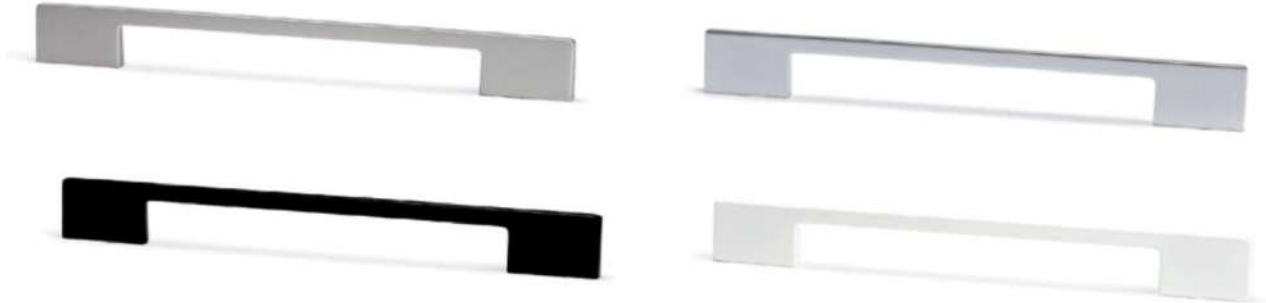
tirador asa MONTILLA

ZAMAK

					efecto inox mt	SK	
	96	152	20	26	113.811.015	✓	1

tirador asa ARA

ZAMAK

					cromo look	SK	
	128	146	10	35	113.811.264	✓	1
	192	208	10	35	113.811.675	✓	1

tirador asa THEO eco

ZAMAK

					cromo look	SK	
	128	154	8	26	111.811.706	✓	1
	160	193	8	26	111.811.194	✓	1





tirador asa

21.03 tirador asa SENA

ZAMAK

					chromo look	SK	
160	240	30	30	113.811.206	✓	1	



tirador asa DIAL

ZAMAK

					chromo look	SK	
128	154	20	30	113.811.216	✓	1	



tirador asa ITALO

ZAMAK

				chromo mate	chromo brillo	SK	
128	167	19	30	111.811.094	111.811.825	✓	1



tirador asa HERI

ZAMAK

				chromo look	chromo brillo	SK	
128	151	13	27	111.811.376	113.811.656	✓	1



tiradores



tirador asa DUBLIN

ALUMINIO

					aluminio mate	chromo brillo	SK	
192	204	12	30	111.811.874	111.811.922	✓	1	
280	292	12	30	111.811.885		✓	1	
380	392	12	30	111.811.896	111.811.944	✓	1	
580	592	12	30	111.811.900	111.811.955	✓	1	
390-780	782	12	30	111.811.911		✓	1	

tirador asa TODAY

ZAMAK

					chromo brillo	ef.inox mate	SK	
128	136	12	26	111.811.162	111.811.173	✓	1	
192	136	12	26	111.811.184	111.811.199	✓	1	

tirador asa THIN-K

ZAMAK

					ef.inox mate	SK	
160	180	4	25	113.811.311	✓	1	

tirador asa PRONTO

ZAMAK

					efecto inox mt	chromo brillo	oro rosa mt	SK	
128	134	10	30	111.811.322	111.811.344	113.811.770	✓	1	
160	134	10	30	111.811.333	113.811.355		✓	1	





tirador asa

21.03 tirador asa GEA

ZAMAK

					chromo look	SK	
160	175	10	36	113.811.412	✓	1	



tirador MICAEL

ZAMAK

					chromo mate	SK	
64	80	25	28	113.811.742	✓	1	



tirador asa ROMA

ZAMAK

					ef.inox mate	SK	
192	207	14	30	113.811.743	✓	1	
320	335	14	30	113.811.754	✓	1	



tirador asa ARKO

ZAMAK

					ef.inox mate	SK	
160	186	20	32,5	113.811.620	✓	1	
256	292	20	32,5	113.811.631	✓	1	



tiradores





tirador 192

ZAMAK	chromo br	oro	chromo mt	epoxi pintura	niquel sat.	cuero decor.	SK
	113.389.192	113.389.193	113.389.194	113.389.xxx	113.389.226	113.389.227	10

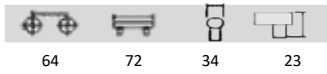

Para pedidos color epoxi indicar el color RAL.

COLORES EPOXI / EPOXY COLORS



tirador 193

ZAMAK	chromo br	oro	chromo mt	epoxi pintura	niquel sat.	cuero decor.	SK
	113.389.230	113.389.231	113.389.232	113.389.xxx	113.389.265	113.389.266	10



Para pedidos color epoxi indicar el color RAL.

COLORES EPOXI / EPOXY COLORS





tirador asa

21.03 tirador 141 y 164

ZAMAK	chromo br	oro	chromo mt	epoxi pintura	niquel sat.	cuero decor.	SK	
mod.141	113.389.141	113.389.142	113.389.143	113.389.xxx	113.389.175	113.389.176		10
mod.164	103.389.064	103.389.065	103.389.066	103.389.xxx	103.389.136	103.389.137		10

mod.141	32	58	23	18
mod.164	32	52	29	21



141



164

Para pedidos color epoxi indicar el color RAL.

COLORES EPOXI / EPOXY COLORS



tirador asa EKAI

ZAMAK					chromo look	SK	
	160	168	12	27	113.811.635		1



tirador asa MONTORO

ZAMAK					efecto inox mt	SK	
	32	53	19	23	113.811.004		1
	96	130	16	25	113.811.993		1



tiradores







p= bajo pedido

stock

tirador asa SQUARE





ZAMAK

				efecto inox mt	chromo brillo	SK	
	12	12	24	115.811.956	115.811.960	✓	1
96	114	11	30	113.811.934	113.811.945	✓	1
128	141	12	30	113.811.912	113.811.923	✓	1



tirador asa DRY

ZAMAK

				efecto inox mt	blanco brillo	negro mate	SK	
160	175	5	31	111.811.611	111.811.622	111.811.633	✓	1



tirador asa RENZO





ZAMAK

				chromo look	SK	
64	114	12	15	114.811.263	✓	1



tirador asa TRAIL

ZAMAK

				efecto inox mt	SK	
16	48	26	32	113.811.711	✓	1
128	154	19	32	113.811.744	✓	1





tirador asa

21.03 tirador asa LOUNGE

ZAMAK

				efecto inox mt	negro mate	SK	
160	174	7	35	115.811.980	115.811.991	✓	1



tirador asa NEK

ZAMAK

				efecto inox mt	negro mate	SK	
160	172	7	33	115.811.831	115.811.853	✓	1
320	332	7	35	115.811.842	115.811.864	✓	1



tirador asa VISTA

ZAMAK

				efecto inox mt	titanio	SK	
160	176	10	38	116.811.696	116.811.153	✓	1



tirador asa CREEK

ZAMAK





				efecto inox mt		SK	
160	169	9	32	116.811.186		✓	1





tirador asa GEA



ZAMAK

				efecto inox mt	SK	
	34	34	28	111.811.571	✓	1
160	186	18	38	111.811.604	✓	1



tirador asa BAMBOO





ZAMAK

				efecto inox mt	SK	
160	176	16	35	112.811.630	✓	1



tirador asa CORAL

ZAMAK

				cromo mate	cromo brillo	SK	
160	187	7	30	115.811.045	115.811.056	✓	1
240	280	8	35	115.811.395	115.811.406	✓	1
352	400	7	35	115.811.410	115.811.421	✓	1

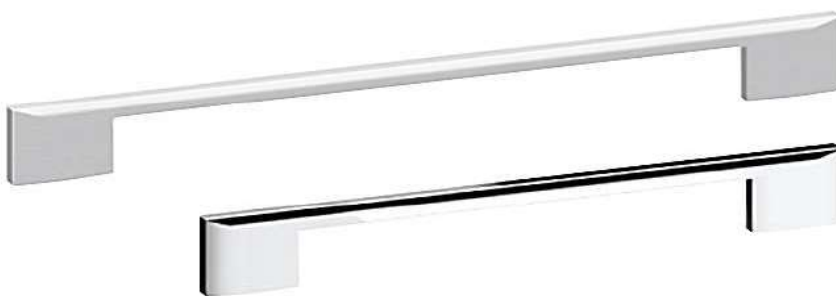



tirador DANILO

ALUMINIO

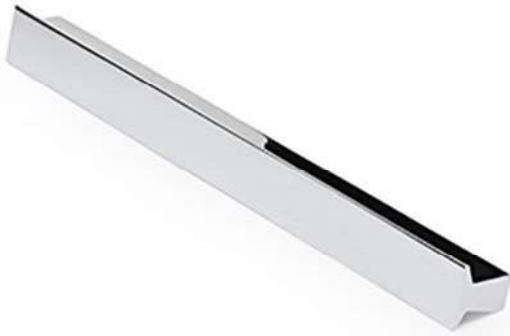

					acabado	SK	
64	100	13	14	cromo brillo	111.811.283	✓	1
96-128	200	13	14	cromo brillo	111.811.294	✓	1

tirador COSME

ALUMINIO



					aluminio mate	cromo brillo	SK	
64	200	16	16	aluminio mate	111.811.182	111.811.215	✓	1
128	300	16	16	aluminio mate	111.811.192	111.811.226	✓	1
192	500	16	16	aluminio mate	111.811.204	111.811.237	✓	1

tirador DUBAI

ALUMINIO



					aluminio mate	SK	
32	45	11	19,5	aluminio mate	114.811.213	✓	1
96	120	11	19,5	aluminio mate	114.811.224	✓	1
128	150	11	19,5	aluminio mate	114.811.260	✓	1
160	190	11	19,5	aluminio mate	114.811.236	✓	1
256	300	11	19,5	aluminio mate	114.811.246	✓	1

					cromo brillo	SK	
64	100	11	19,5	cromo brillo	114.811.143	✓	1
128	200	11	19,5	cromo brillo	114.811.154	✓	1
192	300	11	19,5	cromo brillo	114.811.165	✓	1
256	400	11	19,5	cromo brillo	114.811.176	✓	1
416	500	11	19,5	cromo brillo	114.811.180	✓	1
512	600	11	19,5	cromo brillo	114.811.191	✓	1
640	900	11	19,5	cromo brillo	114.811.202	✓	1

tirador MINUS

ZAMAK



					cromo look	SK	
32	41	10	20	cromo look	114.811.235	✓	1
96	105	10	20	cromo look	111.811.250	✓	1



tirador

21.04 tirador FALL

ZAMAK

				efecto inox mt	negro cepill.	SK	
16	18	20	30	111.811.083	111.811.094	✓	
128	140	20	30	111.811.105	111.811.116	✓	1



tirador TARJETERO

ZAMAK

				laton oxidado	SK	
32	81	52	20	113.811.033	✓	1



tirador XENO

ZAMAK

				chromo look	SK	
64-128	148	9	20	111.811.124	✓	1



tirador SQUADRA

ALUMINIO

			cuero	champagne	gris plata	chromo brillo	SK	
32	50	15	113.557.327	113.557.328	113.557.329	113.557.330		10
64	100	15	113.557.648	113.557.643	113.557.644	113.557.645		10
96	150	15	113.557.658	113.557.659	113.557.660	113.557.661		10
128	200	15	113.557.287	113.557.288	113.557.289	113.557.290		10
160	250	15	113.557.649	113.557.650	113.557.651	113.557.652		10
192	300	15	113.557.749	113.557.750	113.557.751	113.557.752		10



chromo brillo

champagne

gris plata

cuero

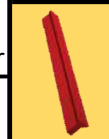
tirador BASIC

ZAMAK

					chromo brillo	ef.inox mate	SK	
64	96	33	19,7		116.811.772	116.811.783	✓	1
160	192	33	19,7		116.811.794	116.811.805	✓	1

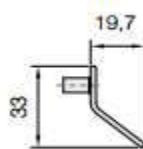
tirador OLA

ZAMAK

					aluminio mate	chromo brillo	SK	
64	145	10	18		115.811.213	115.811.246	✓	1
160	280	10	20		115.811.224	115.811.250	✓	1
256	446	11	20		115.811.235	115.811.261	✓	1

tirador 157

ALUMINIO

					epoxi pintura	chromo brillo	SK	
32	96	14	14		115.389.xxx	115.389.157		1
64	128	14	14		115.389.xxx	115.389.158		1
96	160	14	14		115.389.xxx	115.389.159		1
128	192	14	14		115.389.xxx	115.389.160		1
192	256	14	14		115.389.xxx	115.389.161		1
256	320	14	14		115.389.xxx	115.389.162		1
292	356	14	14		115.389.xxx	115.389.163		1
392	456	14	14		115.389.xxx	115.389.164		1
492	556	14	14		115.389.xxx	115.389.165		1
592	656	14	14		115.389.xxx	115.389.166		1
692	756	14	14		115.389.xxx	115.389.167		1
792	856	14	14		115.389.xxx	115.389.168		1
1020	956	14	14		115.389.xxx			1

Para pedidos color epoxi indicar el color RAL.

COLORES EPOXI / EPOXY COLORS



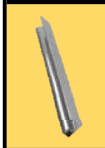

tirador

21.04 tirador 156

ALUMINIO

					epoxi pintura	chromo brillo	SK	
	32	96	16	16	114.389.xxx	114.389.156		1
	64	128	16	16	114.389.xxx	114.389.157		1
	96	160	16	16	114.389.xxx	114.389.158		1
	128	192	16	16	114.389.xxx	114.389.159		1
	192	256	16	16	114.389.xxx	114.389.160		1
	256	320	16	16	114.389.xxx	114.389.161		1
	292	356	16	16	114.389.xxx	114.389.162		1
	392	456	16	16	114.389.xxx	114.389.163		1
	492	556	16	16	114.389.xxx	114.389.164		1
	592	656	16	16	114.389.xxx	114.389.165		1
	692	756	16	16	114.389.xxx	114.389.166		1
	792	856	16	16	114.389.xxx	114.389.167		1
	1020	956	16	16	114.389.xxx			1



Para pedidos color epoxi indicar el color RAL.

COLORES EPOXI / EPOXY COLORS



tirador DUBA

ALUMINIO

					aluminio mate	SK	
	64	80	13	20	114.811.603		1





pomo STELA





ZAMAK

				aluminio look	SK	
16	30	20	20	113.811.373	✓	1



pomo FLAT





ACERO INOX

				inox mate	SK	
16	36	30	30	111.811.691	✓	1



pomo DUAL

ZAMAK

				chromo brillo	chromo mate	SK	
16	26	10	26	113.811.776	113.811.802	✓	1



tirador asa QUANTO





ZAMAK

				chromo look	SK	
32	42	10	28	116.811.193	✓	1



tirador asa TONIC

ZAMAK

				efecto inox	blanco mate	negro mate	SK	
25	25	19	31	111.811.644	111.811.655	116.811.666	✓	1





tiradores

21.05 pomo FREM cuadrado 25x25

ZAMAK

cuero	efecto inox	chromo mate	chromo brillo	SK	
116.557.819	116.557.820	116.557.821	116.557.822		25



pomo pendulo movil HANG

ZAMAK

			chromo look	SK	
20	36	7	115.811.646		1



tirador COMODILLA

ZAMAK

			cuero	oro	chromo look	SK	
79	36	6	115.811.803	116.131.801	116.811.254		1



tirador OVAL COMODILLA

ZAMAK

		cuero	oro	SK	
36	36	116.131.363	116.131.361		10



tiradores



b



tirador LARA





ZAMAK

				chromo look	SK	
32	44	44	4,5	115.811.391	✓	1



tirador LUNA





ZAMAK

				chromo brillo	SK	
64	74	40	19	115.811.710	✓	1



tirador BLOCK





ZAMAK

				efecto inox mt	SK	
16	37	25	21	115.811.155	✓	1



tirador LONDRES

ZAMAK

				ef.inox mate	chromo brillo	SK	
32	50	40	29	115.811.036	115.811.062	✓	1
32	60	60	32	115.811.040	115.811.079	✓	1





21.05 tirador WING

ZAMAK

				ef.inox mate	blanco mate	SK	
16	98	39	23	115.811.510	115.811.521	✓	1



pomo BENE

ZAMAK

			cromo mate	SK	
29	30	26	115.811.315	✓	1



pomo SETA

ALUMINIO

			cromo look	SK	
28	28	25	115.811.701	✓	1



tirador SUN

ZAMAK



				cromo look	SK	
32	88	15	33	115.131.522	✓	1





pomo DIAL





ZAMAK

			cromo look	blanco mate	negro mate	SK	
28	28	25	115.811.384	115.811.044	115.811.055	✓	1



pomo DELTA





PORCELANA

			blanco	SK	
32	32	25	115.811.176	✓	1



pomo RAMI

ACERO INOX

			inox mate	SK	
20	20	17	116.811.956	✓	1
30	30	25	115.811.966	✓	1



pomo SFERA

ZAMAK

			cromo mate	cromo brillo	blanco	dorado brillo	SK	
50	40	29	116.811.686	116.811.272	116.811.284	116.811.866	✓	1





21.05 pomo GUSTA-ECO

ZAMAK

				efecto inox	SK	
	20	20	24	115.811.961	✓	1



pomo GUSTA y GUALTE

ACERO INOX



				inox mate	SK	
GUSTA	15	15	26	116.811.936	✓	1
GUSTA	20	20	28	116.811.142	✓	1
GUALTE	25	25	30	116.811.451	✓	1
GUALTE	30	30	35	116.811.440	✓	1



GUSTA



GUALTE

pomo ATENEA

ZAMAK

				efecto inox	SK	
	28	28	24	115.811.935	✓	1
	34	34	26	115.811.946	✓	1



pomo KUBE y KUBE B

ACERO INOX

tipo				inox mate	SK	
kube	10	10	24	115.811.443	✓	1
kube	15	15	30	115.811.454	✓	1
kube B	10	10	22	115.811.043	✓	1
kube B	15	15	25	115.811.054	✓	1



KUBE



KUBE B



21.05

pomo ZAPA





ZAMAK

	cromo brillo	ef.inox mate	SK	
20	115.811.642	115.811.653	✓	1



pomo JAYCO





ZAMAK

			cromo look	SK	
25	16	15	115.811.004	✓	1



pomo PEON

ZAMAK

			cromo look	dorado brillo	SK	
15	15	25	116.811.283	115.811.955	✓	1



pomo ANDONI





ACERO INOX

			inox mate	SK	
12	12	22	116.811.286	✓	1



pomo GENA

ALUMINIO

			inox mate	blanco mate	negro mate	marron chocol.	SK	
16	16	24	115.811.194	115.811.941	115.811.952	115.811.963	✓	1





tiradores

21.05 tirador CIRIL

ZAMAK

			chromo look	SK	
30	30	9	115.811.134	✓	1



pomo CUBO

ZAMAK

			chromo mate	SK	
16	44	17	116.811.664	✓	1



pomo HOOK

ZAMAK

			ef.inox mate	chromo brillo	SK	
30	20	28	115.811.944	115.811.933	✓	1



tirador FRUIT

ZAMAK/
ACRILICO





			cr br/lima	cr br/marron	cr.br/naranja	cr.br/rojo	SK	
40	38	28	116.811.970	116.811.981	116.811.992	116.811.003		25
					cr.br/blanco	cr.br/negro	SK	
					116.811.955	116.811.966	✓	1





pomo AXIS





ALUMINIO

			alum.cepillado	SK	
15	15	24	115.811.073	✓	1
20	20	28	115.811.084	✓	1



pomo VELA





ZAMAK

			ef.inox mate	Cromo brillo	SK	
40	20	30	115.811.804	115.811.815	✓	1



pomo GRAF





ALUMINIO

			ef.inox mate	Cromo brillo	SK	
18	18	28	115.811.922	115.811.852	✓	1



pomo DUNA

ZAMAK

		Cromo brillo	cuero decorado	niquel decor.	cuero	SK	
40	40	108.557.950	108.557.952	108.557.954	108.557.956		10
60	60	108.557.951	108.557.953	108.557.955	108.557.957		10



Cromo brillo

niquel decorado

otros acabados consultar.



21.05 pomo PLANO

ZAMAK



		chromo brillo	cuero	SK	
55	35	108.557.417	108.557.419		10
45	30	108.557.418	108.557.420		10

otros acabados consultar.

pomo LLAVE

ZAMAK



		chromo brillo	cuero	SK	
40	40	108.557.815	108.557.817		10
60	60	108.557.816	108.557.818		10

otros acabados consultar.

tirador ABRIL

ZAMAK



			chromo brillo	cuero	SK	
64	68	68	108.557.800	108.557.802		10
44	54	54	108.557.801	108.557.803		10

otros acabados consultar.

pomo BOLA 20

ZAMAK

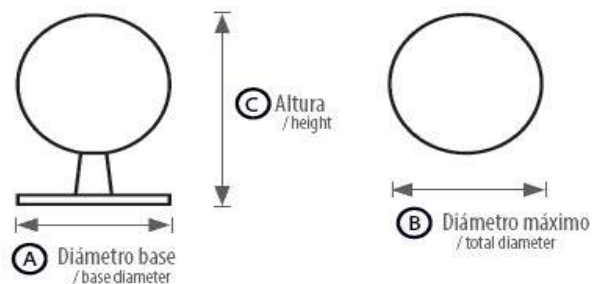

A	B	C	epoxi pintura	chromo brillo	chromo mate	níquel satinado	SK	
18	20	26	116.389.xxx	116.389.100	116.389.103	116.389.104		25
23	25	30	116.389.xxx	116.389.101	116.389.108	116.389.105		25
28	30	35	116.389.xxx	116.389.102	116.389.109	116.389.106		25

Para pedidos color epoxi indicar el color RAL.





pomo BOLA 21

ZAMAK

A	B	C	epoxi pintura	chromo brillo	chromo mate	niquel satinado	SK	
13	20	20	116.389.xxx	116.389.200	116.389.203	116.389.204		25
13	25	20	116.389.xxx	116.389.201	116.389.214	116.389.205		25
18	32	28	116.389.xxx	116.389.202	116.389.215	116.389.206		25

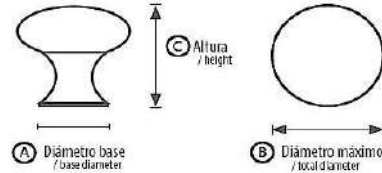

pomo SCOPE

ZAMAK

Para pedidos color epoxi indicar el color RAL.

30	16	20	efecto inox mt	negro mate	SK	
			113.811.634	113.811.645		1



pomo EGG

ZAMAK

Para pedidos color epoxi indicar el color RAL.

20	28	26	chromo brillo	efecto inox mt	SK	
			113.811.641	113.811.652		1



pomo anilla TREASURE

ZAMAK

30	52	68	20	efecto inox mt	SK	
				113.811.534		1



pomo CURTAIN

ACERO INOX

50	20	40	60	22	45	acero inox	SK	
						116.811.383		1
						116.811.394		1





21.05 pomo AUTUM

ZAMAK



				negro mate	SK	
	28	28	27	115.811.164	✓	
	36	36	34	115.811.175	✓	1

pomo BOLA RV5

ZAMAK



	A	B	C	laton pulido	cuero	níquel satinado	SK	
	20	20	25	116.131.020		116.131.024		10
	25	25	30	116.131.021	116.131.023	116.131.025		10
	30	30	36	116.131.022		116.131.026		10

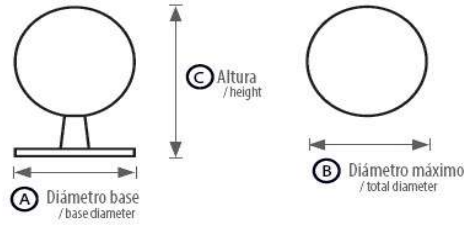

pomo ZEPELIN

ZAMAK



				negro mate	SK	
	52	21	40	115.811.120	✓	1

pomo PHARMA

ZAMAK



				efecto inox m	SK		
	64	95	38	22	115.811.560	✓	1

ZAMAK



				efecto inox m	SK	
	60	35	36	115.811.501	✓	1





21.06

tirador PANFI

PIEL





				mate-marron	SK	
64	168	21	27	106.811.023	✓	1



tirador TOME

ZAMAK





POLIEPIEL

				mate-café	SK	
64	74	11	20	106.811.353	✓	1



tirador NERI





ZAMAK/PIEL

				marron	SK	
	43	43	22	106.811.754	✓	1
96	138	35	22	106.811.776	✓	1



tirador SAFARI

ZAMAK/CUERO

				efecto inox mt/cuero negro	efecto inox mt/cuero marron	SK	
16	24	67	35	116.811.663	106.811.142	✓	1
160	224	24	25	116.811.674		✓	1





tiradores

21.06 tirador asa OROS cromo mate marron

ZAMAK/piel

				cr.mt.marron	SK	
128	214	20	40	106.811.791	✓	1
544	628	20	40	106.811.813	✓	1



tirador asa MILANO

ZAMAK/PIEL

				mate-beige	mate-marron	SK	
492	506	30	34	116.131.150	116.811.161	✓	1

tirador PESTAÑA

ZAMAK/PIEL

				mate arena	SK	
16	25	45	20	116.811.342	✓	1





21.07

tirador asa SYMBIOSIS

ZAMAK

MADERA

					cr.mt.wengue	cr.mt.haya	SK	
		21	21	29	107.811.591	107.811.602	✓	1
	128	144	12	29	107.811.576	107.811.580	✓	1

tirador EDGE WOOD

ALUMINIO

ROBLE

			efecto inox mate-madera roble			SK	
	20	40				✓	1
	160*	200				✓	1

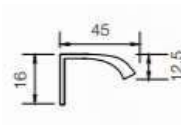

* Tiradores con 3 agujeros a 80 mm de distancia.

pomo OPALE

ACRILICO

				blanco	marron aguas	marron oscuro	SK	
	38	38	20	107.811.614	107.811.625	107.811.603	✓	1

tirador NATURE

MADERA

					roble antiguo	wengue	SK	
	16	55	55	22	107.811.775	107.811.764	✓	1
	192	240	30	22	107.811.753	107.811.742	✓	1





21.07 tirador TACCO

MADERA

* Tiradores con 3 agujeros a 80 mm de distancia.

				freno	nogal	haya cruda	SK	
32	94	84	16	107.811.792	107.811.803	107.811.814*	✓	1

* Sin barnizar



tirador BARCCO

MADERA

				fresno	nogal	SK	
160	200	18	33	107.811.825	107.811.851	✓	1
320	400	18	33	107.811.836	107.811.862	✓	1
320/480	600	18	33	107.811.840	107.811.873	✓	1



pomo 38

MADERA

			roble	pino	haya	nogal	SK	
30	30	30	107.389.038	107.389.041	107.389.044	107.389.047		10
35	35	31	107.389.039	107.389.042	107.389.045	107.389.048		10
40	40	30	107.389.040	107.389.043	107.389.046	107.389.049		10



posibilidad de acabado crudo , consultar.

pino lacado

pomo 40

MADERA

			roble	pino	haya	nogal	SK	
30	30	32	107.389.050	107.389.052	107.389.054	107.389.056		10
35	35	36	107.389.051	107.389.053	107.389.055	107.389.057		10



roble lacado

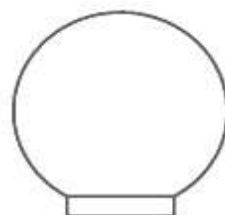

posibilidad de acabado crudo , consultar.



haya lacado







21.07

tirador asa ARA W

ALUMINIO





MADERA

					roble-ef. inox	nogal-ef.inox	SK	
	160	200	15	32	107.811.770	107.811.781	✓	1



tirador MANTA





MADERA

					roble	haya	SK	
	32	80	24	26	107.811.346	107.811.350	✓	1
	160	240	24	26	107.811.361	107.811.372	✓	1



tirador pomo RELOJ LORD





MADERA

				haya	SK	
	40	40	29	107.811.562	✓	1



tirador pomo RELOJ DON

MADERA

				haya miel	SK	
	40	40	29	107.811.573	✓	1





21.07 tirador pomo RELOJ CHIC

MADERA

			decapé	SK	
40	40	29	107.811.551	✓	1



tirador pomo RELOJ PARIS

MADERA

			nogal	SK	
40	40	29	107.811.584	✓	1



tirador pomo RACER CAR

MADERA

			nogal	SK	
40	40	29	107.811.595	✓	1



tirador pomo RACER PICK

MADERA

			haya	SK	
40	40	29	107.811.606	✓	1



tirador pomo RACER BIG VALVE

MADERA

			haya miel	SK	
40	40	29	107.811.621	✓	1



tirador pomo RACER MOTHER

MADERA

			haya miel	SK	
40	40	29	107.811.610	✓	1









tirador CENTURY





MADERA



modelo				blanco decape	gris decape	SK	
bola	35	35	35	107.811.632	107.811.643	✓	1
corazon	37	39	25	107.811.654	107.811.665	✓	1

pomo ESTRELLA

MADERA

			azul	blanco	rosa	gris	SK	
67	65	25	107.811.385	107.811.400	107.811.396	107.811.530	✓	1



pomo NUBE

MADERA

			azul	blanco	rosa	gris	SK	
68	58	25	107.811.411	107.811.433	107.811.422	107.811.541	✓	1



pomo ESFERA

MADERA

			azul	blanco	rosa	gris	SK	
40	40	37	107.811.444	107.811.466	107.811.455	107.811.452	✓	1

