

Mecanizado del marco.

Utiles necesarios:

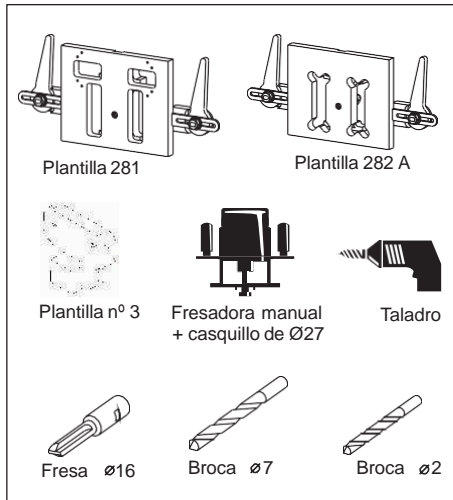

Medidas mecanizados

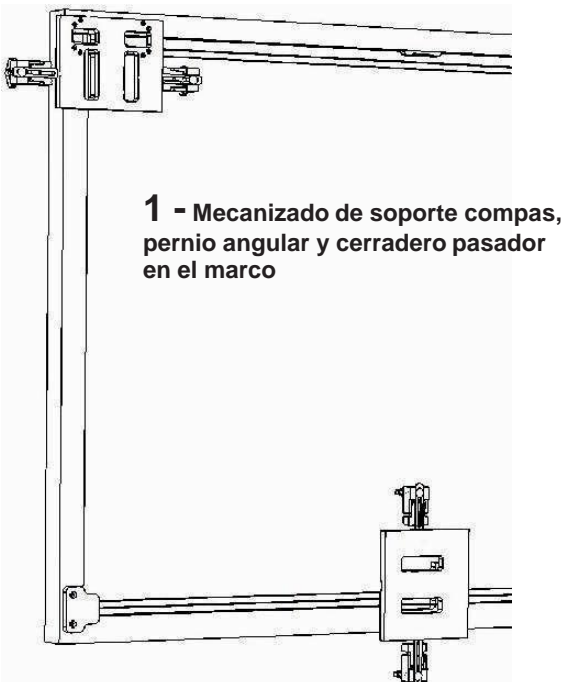
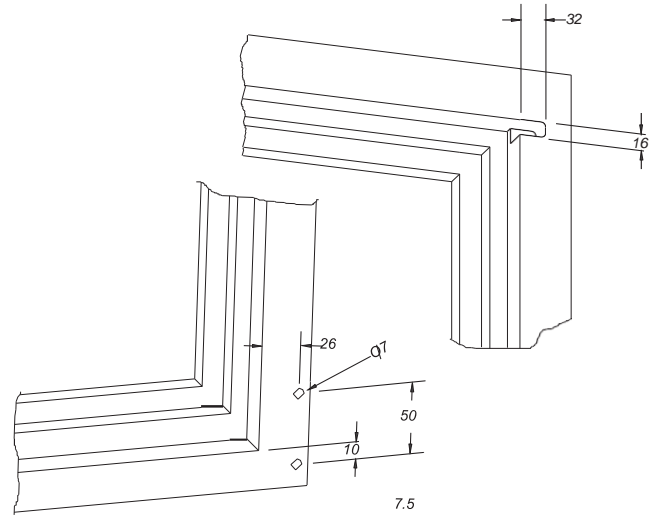

Mecanizado de la hoja.

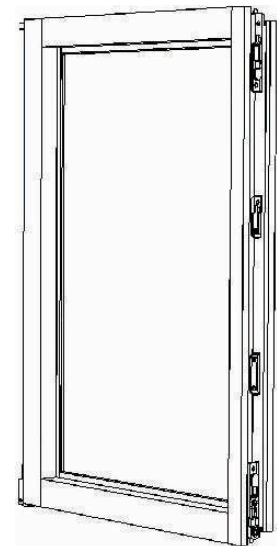
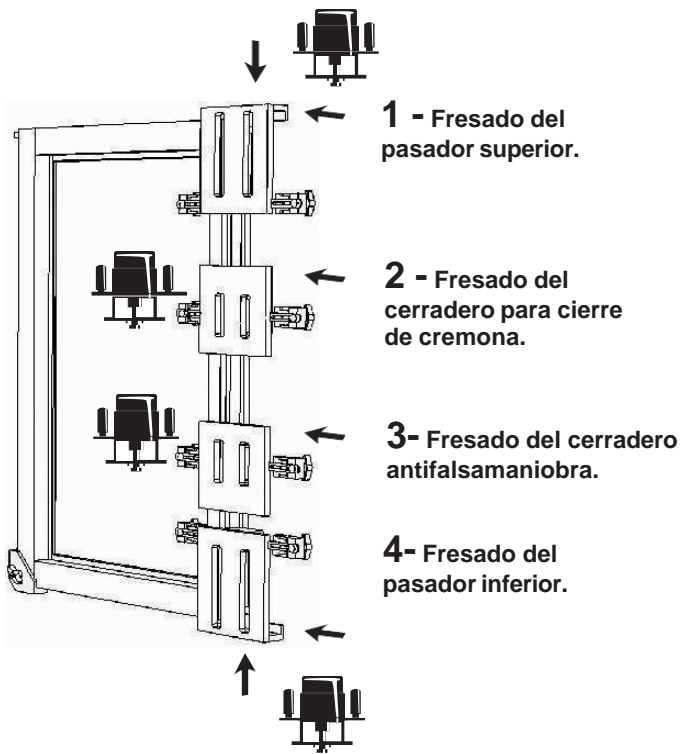

5 - Colocacion pasadores y cerraderos a la hoja.

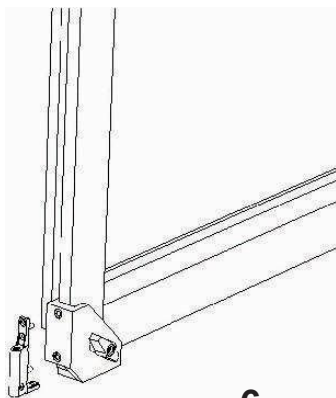

6 - Taladrado y colocacion pernio angular en el marco.



7 - Fijar el Falso Soporte Compas a la hoja.