

Titus+

Cam3000 cross drive

cabeza pz/enrasado

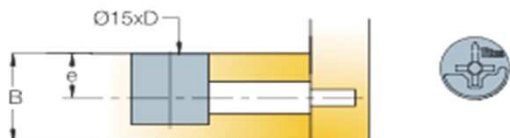

Referencia	B	D	e	h	item	Acabado	SK
412.334.495	12/13	10,5	6,5min	9,9	09495	zinc	✓
412.334.533	15/16	12,5	7,5-8	11,9	09533	zinc	🕒

Embalaje 1000 unid.

Titus+

Cam3000 hexagonal drive

cabeza hex/pz enrasado

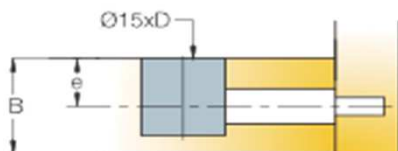
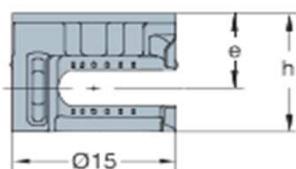

Referencia	B	D	e	h	item	Acabado	SK
412.334.537	15/16	12,5	6,5min	9,9	09537	zinc	✓
412.233.536	18/19	14	7,5-8	11,9	09536	zinc	✓

Embalaje 1000 unid.

combined drive with HEX



Titus+

Cam2000 Ø15

cabeza hex/pz enrasado

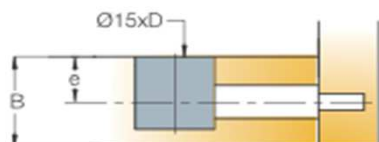
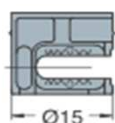

Referencia	B	D	e	h	item	Acabado	SK
412.334.653	12/13	10min	6-6,5	pz	05653	zinc	✓
412.334.654	15/16	12,7	7,5-8		05654	zinc	✓
412.334.656	18/19	14	9-9,5		05656	zinc	✓
412.334.657	22/23	16	11-11,5		05657	zinc	✓
412.334.676	25/26	17,9	12,5-13		05676	zinc	✓
412.334.678	28/29	19,4	14-15,5		05678	zinc	✓

Embalaje 1000 unid.



**Titus+**

Cam2000  
Ø15 headed

**cabeza hex/pz  
reborde**

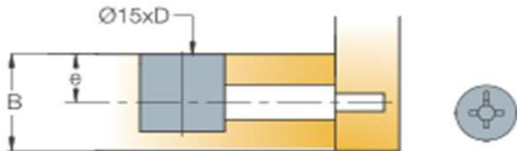
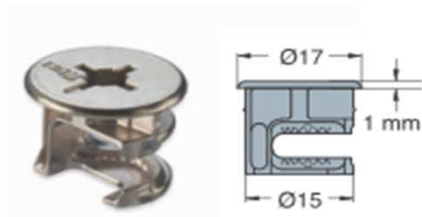

Referencia	B	D	e	item	Acabado	SK
412.334.652	13	10,9min	6,5	05652	zinc	
412.334.658	16	12,9	8	05658	zinc	
412.334.659	19	13	9,5	05659	zinc	
412.334.675	23	14,5	11,5	05675	zinc	
412.334.676	26	16,5	13	05677	zinc	
412.334.679	29	19,4	14,5	05679	zinc	

Embalaje 1000 unid.

**Titus+**

Cam2000  
Ø12

**cabeza hex/pz  
enrasado**

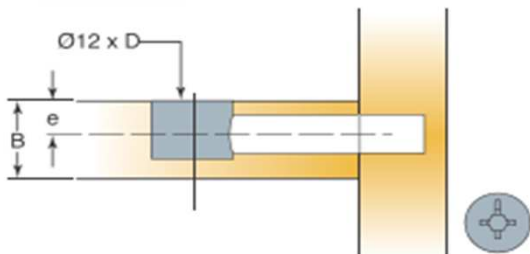
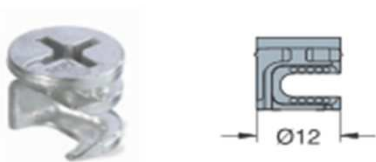

Referencia	B	D	e	item	Acabado	SK
412.334.575	12/13	10min	6-6,5	05575	zinc	
412.334.578	15/16	12	7,5-8	05578	zinc	
412.334.580	18/19	13min	9-9,5	05580	zinc	

**Titus+**

Cam2000  
Ø12 headed

**cabeza hex/pz  
reborde**

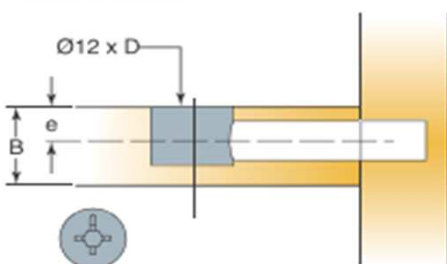
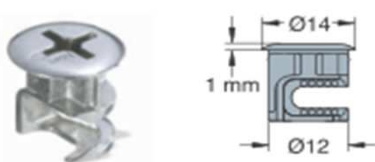

Referencia	B	D	e	item	Acabado	SK
412.334.574	12	9,2min	5,25	05574	zinc	
412.334.576	12	10min	6	05576	zinc	
412.334.579	16	12,5	8	05579	zinc	



**Titus+**

Cam3000 S/15

**cabeza pz/enrasado**

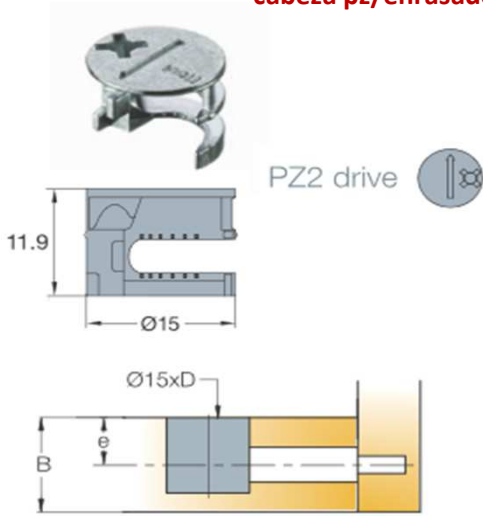

Referencia	B	D	e	item	Acabado	SK
412.334.491	15/16	12,5	7,5-8	09491	zinc	

Embalaje 1000 unid.

**Titus+**

**cabeza pz/enrasado**

Cam3000 S/12

PZ2 drive

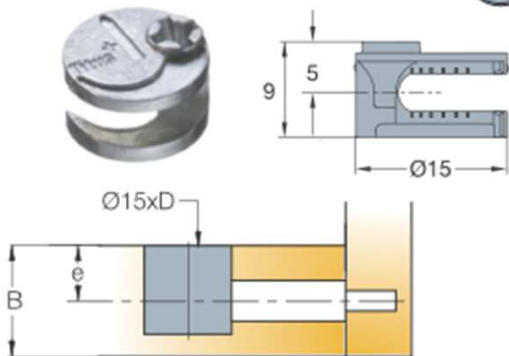

Referencia	B	D	e	item	Acabado	SK
412.334.406	12	9,5	6	09406	zinc	

Embalaje 2000 unid.





**Titus+**

Quickfit-TL2

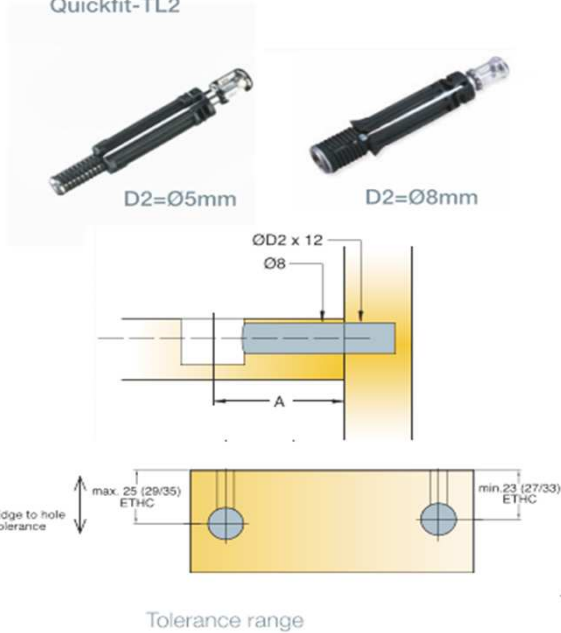

Referencia	A	D2	item	Acabado	SK
412.334.453	24	5	05453	gris	
412.233.503	34	5	05503	gris	
412.233.441	24	8	05441	gris	
412.233.314	28	8	05314	gris	
412.233.474	34	8	05474	gris	

Embalaje 2000 unid.

**Titus+**

Quickfit-TL4

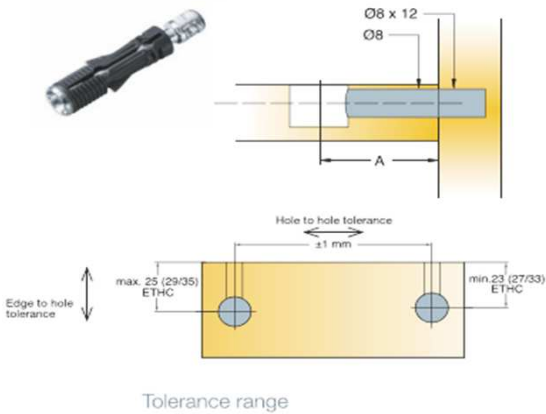

Referencia	A	D2	item	Acabado	SK
412.334.388	24	8	05388	gris	

Embalaje 2000 unid.

**Titus+**

Quickfit dowel  
Ø5mm

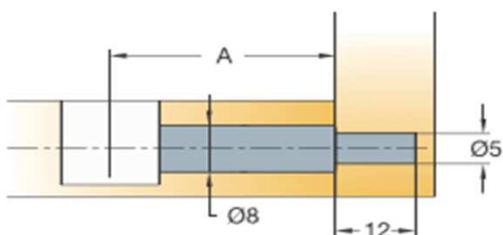

Referencia	A	D2	item	Acabado	SK
412.334.714	24	5	05714	gris	
412.334.685	34	5	05685	gris	

Embalaje 2000 unid.



Disponible  
Consultar



**Titus+**

Quickfit dowel  
Ø8mm

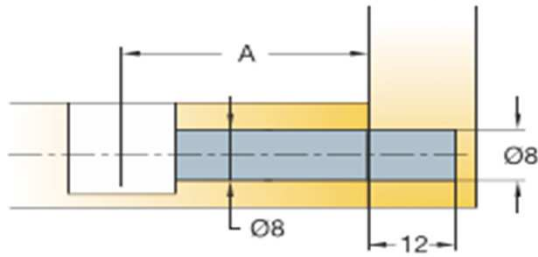

Referencia	A	D2	item	Acabado	SK
412.334.556	20	8	05556	gris	
412.233.563	24	8	05563	gris	
412.233.552	28	8	05552	gris	
412.233.554	34	8	05554	gris	

Embalaje 2000 unid.

**Titus+**

Quickfit dowel  
Ø10mm

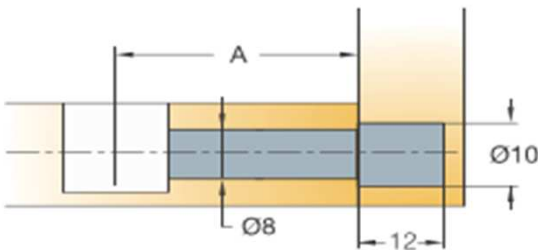

Referencia	A	D2	item	Acabado	SK
412.334.137	24	10	05137	gris	
412.334.129	34	10	05129	gris	

Embalaje 2000 unid.

**Titus+**

Quickfit - P2F

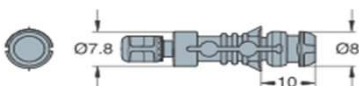

Referencia	A	D2	item	Acabado	SK
412.334.414	24	8	05414	gris	

Embalaje 2000 unid.

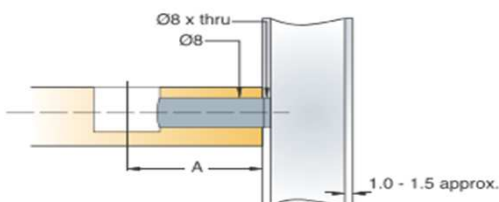

Disponible  
Consultar



**Titus+**

Combi dowel Ø5

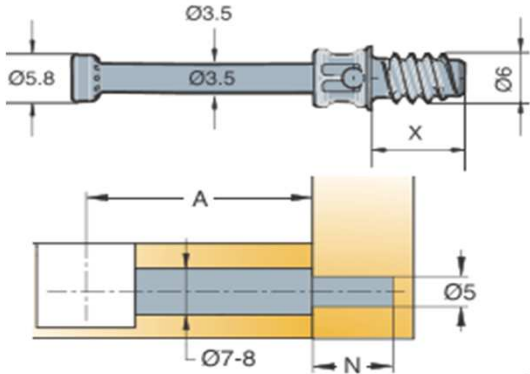

Referencia	A	N	X	item	Acabado	SK
412.334.435	34	12	11	09435	zinc	✓
412.233.588	28	10	9,5	09588	zinc	⌚
412.233.443	24	12	11	09443	zinc	✓
412.233.583	24	9	8,5	09583	zinc	✓

Embalaje 1000 unid.

**Titus+**

Combi dowel M6

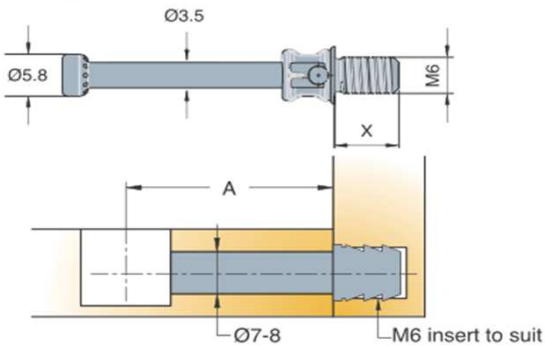

Referencia	A	N	X	item	Acabado	SK
412.334.592	34		8	09592	zinc	✓
412.334.594	34		10,5	09594	zinc	✓

Embalaje 1000 unid.

**Titus+**

Combi dowel Ø5 Full body

PZ2 head

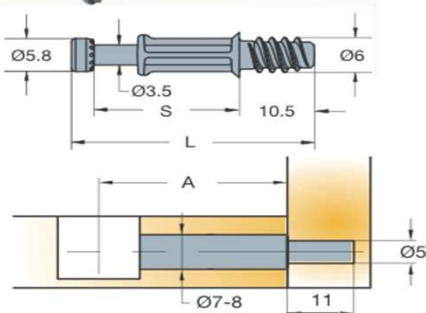

Referencia	S	L	A	item	Acabado	SK
412.334.597	20,6	34,5	24	09597	zinc	⌚

Embalaje 1000 unid.



Disponible

Consultar